

601 CD Ignition System

Installation Instructions

Preparation

Before beginning product installation:

- Read and follow all installation instructions.
- Disconnect all electrical power to the machine.
- Make sure the machine cannot operate during installation.
- Follow all safety warnings of the machine manufacturer.
- A visual inspection of this product for damage during shipping is recommended before mounting.
- It is your responsibility to have a qualified person install this unit and make sure it conforms to NEC and local codes.



Description

A high energy magnet attached to the flywheel passes by a permanently mounted generator coil facing the flywheel. Each time the magnet passes by the face of the generator coil, a capacitor is charged to peak voltage.

A trigger magnet is also mounted on the flywheel and faces off to a trigger coil located on the engine. The trigger coil is positioned so that the magnet will pass the trigger coil and cause the SCR to discharge the storage capacitor into the ignition transformer located near the spark plug.

Long, maintenance-free service is assured because there are no wearing parts. All electronic parts are encapsulated to protect against moisture and physical damage.

Connection Diagram

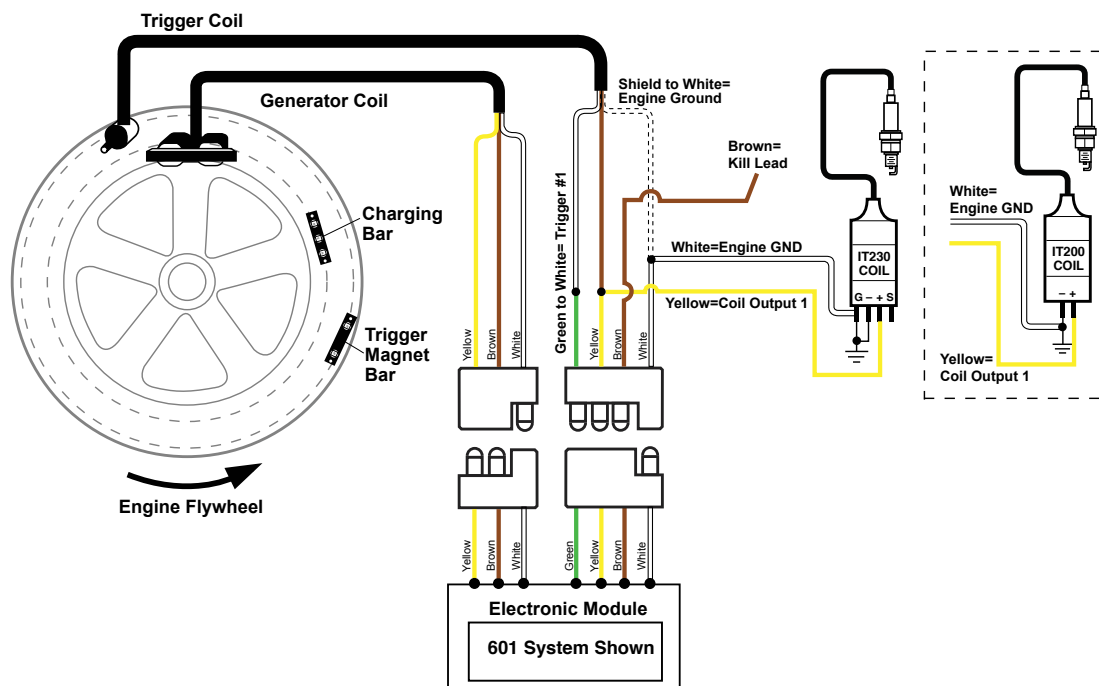

WARNING: The Brown Kill Lead has a potential of 300 to 400 Volts. Exercise extreme caution, and wear appropriate safety equipment.

NOTE: A 100 Ohm, 10 Watt resistor may be connected in series with the Brown Kill Lead to minimize contact arcing of shut-down devices.

Installation

Note: The EM/GC Assembly (EMG) orientation should be assembled in a way that will allow it and cables to avoid contact with the flywheel when mounted on the engine, using a suitable mounting bracket.

1. Assemble the Electronic Module (EM) to the Generator Coil Assembly (GC).
2. Slide the GC threaded screws through the holes in the EM until the EM fits up against the GC.
3. Secure with the two elastic locking nuts provided in the kit. Do not overtighten the nuts.
4. Connect the EM and GC's three position connectors securely together.
5. Locate a convenient place on the engine to install the EMG. The EMG must be mounted so that it is positioned facing the side of the flywheel. (See diagram).
6. The EMG must be positioned with sufficient clearance from the flywheel to allow the magnet bar (which is to be mounted on the flywheel) to pass between the EMG and the flywheel with a nominal 0.030 inch gap between the magnet bar and the EMG.
7. After positioning the EMG, rotate the engine flywheel to the running spark position. Rotate the flywheel an additional 30 degrees in the advance direction or against normal rotation. Mark the flywheel under the EMG and install the magnet bar on the flywheel at this location making sure the three magnets are aligned as much as possible with the three poles of the EMG. The air gap between the EMG and the magnet bar should be a nominal 0.030 inches but no more than 0.080 inches.
8. Locate a place on the engine to mount the Trigger Coil so it will face the side of the flywheel.
9. Position the Trigger Coil at least 2 1/2 inches radially separated from the circle on the flywheel determined by the EMG and its magnet bar.
10. Rotate the engine to the running spark position making sure that the charging bar has cleared the EMG before the recessed advance button magnet in the trigger magnet bar rotates under the trigger coil. Mount the trigger magnet bar with the recessed magnet directly under the trigger coil. The other end of the trigger magnet bar should be against (i.e. the recessed magnet should be leading) the direction of rotation of the flywheel. The trigger magnet bar and the EMG magnet bar should now be located on the flywheel on circles separated by at least 2 1/2 inches.
11. The air gap between the Trigger Coil and the Trigger Magnet Bar should be a nominal 0.035 to 0.080 inches. Engine starting is best at this gap setting.
12. Connect the Trigger Coil and EM's four position connectors securely together.
13. Attach the white wire from the Trigger Coil harness to the negative side of the Ignition Coil and the yellow wire to the positive side. The brown wire from the trigger coil is for engine shutdown.

Dimensions

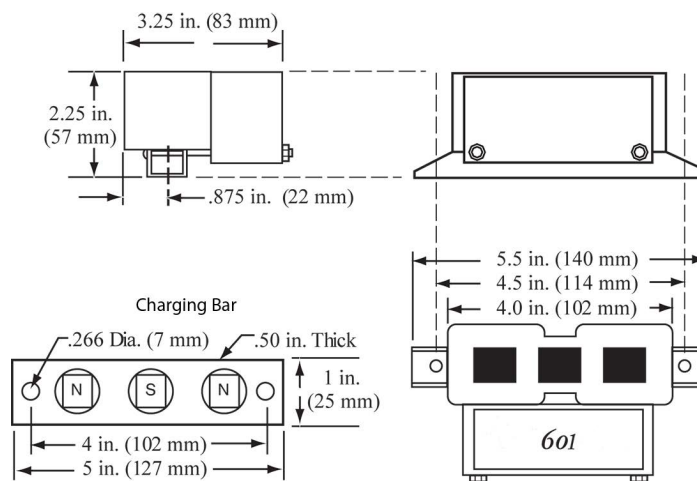

FW MURPHY PRODUCTION CONTROLS

SALES, SERVICES & ACCOUNTING
4646 S. HARVARD AVE.
TULSA, OK 74135

MANUFACTURING

2151 RANDON DYER ROAD
ROSENBERG, TX 77471

5757 FARINON DRIVE
SAN ANTONIO, TX 78249

DOMESTIC SALES & SUPPORT

FW MURPHY PRODUCTS
PHONE: 918 957 1000
EMAIL: INFO@FWMURPHY.COM
WWW.FWMURPHY.COM

FW MURPHY CONTROL SYSTEMS & SERVICES
PHONE: 281 633 4500
EMAIL: CSS-SOLUTIONS@FWMURPHY.COM

INTERNATIONAL SALES & SUPPORT

CHINA
PHONE: +86 571 8788 6060
EMAIL: INTERNATIONAL@FWMURPHY.COM

LATIN AMERICA & CARIBBEAN
PHONE: +1 918 770 8775
EMAIL: INTERNATIONAL@FWMURPHY.COM

SOUTH KOREA
PHONE: +82 70 7951 4100
EMAIL: INTERNATIONAL@FWMURPHY.COM



FM 668576 (San Antonio, TX - USA)
FM 668933 (Rosenberg, TX - USA)



FM 523851 (China) TS 589322 (China)