

MX5 Digital Inputs / Outputs, Analog Inputs / Outputs, Frequency Input

Interchange™ Comm Control Module, MX5 Series

Installation and Operations Manual

Warranty - A limited warranty on materials and workmanship is given with this Murphy product. A copy of the warranty may be viewed or printed by going to <http://www.fwmurphy.com/warranty>.



Please read the following information before installing.

BEFORE BEGINNING INSTALLATION OF THIS FW MURPHY PRODUCT, READ AND FOLLOW ALL INSTALLATION INSTRUCTIONS.

EXPLOSION HAZARD: SUBSTITUTION OF COMPONENTS MAY IMPAIR SUITABILITY FOR CLASS 1, DIVISION 2.

EXPLOSION HAZARD: WHEN IN HAZARDOUS LOCATIONS, TURN OFF POWER BEFORE REPLACING OR WIRING MODULES.

EXPLOSION HAZARD: DO NOT DISCONNECT EQUIPMENT UNLESS POWER HAS BEEN SWITCHED OFF OR THE AREA IS KNOWN TO BE NON-HAZARDOUS.

Please contact FW Murphy Production Controls immediately if you have any questions.

Table of Contents

FW Murphy Interchange Comm Control Module Series.....	1
MX5 Digital Inputs/Outputs, Analog Inputs, MPU.....	1
MX5-A Digital Inputs/Outputs, Analog Inputs/Outputs, MPU.....	1
MX5-D Digital Inputs/Outputs, Analog Inputs, MPU	1
Product Dimensions and Mounting	2
Accessories.....	2
Specifications	2
MX5 Installation Instructions	2
Installation Diagram	3
MX5 Jumper Configuration.....	5
Communications	7
MX5 Expansion Module - Modbus RTU Description	8

THIS PAGE INTENTIONALLY LEFT BLANK

FW Murphy Interchange Comm Control Module Series

The MX5 expansion module provides input/output capability to existing and future FW Murphy Controllers using CANbus proprietary communications. Modbus RTU RS485/RS232 is also provided for other communication requirements. Any mix of MX-Series modules can be added to enable Digital and Analog I/O and Thermocouple inputs for communication and monitoring by the master controller.

MX5 Digital Inputs/Outputs, Analog Inputs, MPU

CSA C/US Listed, Class I, Div. 2 Groups B, C & D

The MX5 module adds Digital input/output, Analog input and magnetic pickup ability to the master controller. It can read up to 24 Digital inputs, 8 Digital outputs, 10 Analog inputs and 1 mpu.

MX5-A Digital Inputs/Outputs, Analog Inputs/Outputs, MPU

CSA C/US Listed, Class I, Div. 2 Groups B, C & D

The MX5 module adds Digital input/output, Analog input/output and mpu ability to the master controller. It can read up to 24 Digital inputs, 8 Digital outputs, 10 Analog inputs, 4 Analog outputs and 1 mpu.

MX5-D Digital Inputs/Outputs, Analog Inputs, MPU

CSA C/US Listed, Class I, Div. 2 Groups B, C & D

The MX5 module adds Digital input/output, Analog input and mpu ability to the master controller. It can read up to 24 Digital inputs, 16 Digital outputs, 10 Analog inputs and 1 mpu.

Product Dimensions and Mounting

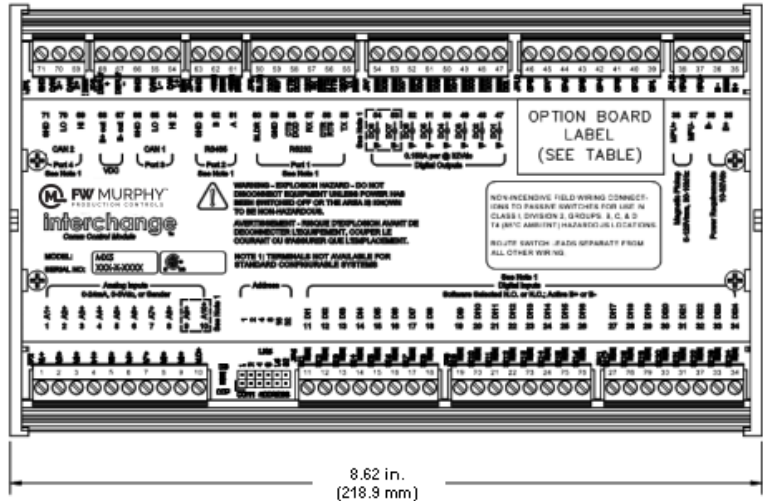
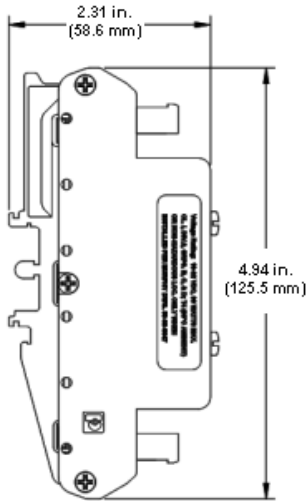

Accessories

MX5 Plug Kit (00030868) Printed Terminal Plugs for MX5 Expansion I/O Module

Specifications

Operating Temperature: -40° to +85° C (185° F)

Storage Temperature: -40° to +85° C (185° F)

Power Input Voltage: 10 to 32 VDC (30W max)

MX5 Installation Instructions

When installing an MX5 Expansion I/O Module, power, I/O (Digitals, Analogs, and MPU) and communication wiring must be in accordance with Class 1, Division 2 wiring methods [Article 501-4(b) of the National Electrical Code, NFPA 70] and in accordance with the authority having jurisdiction.

Installation Diagram

1. FIELD WIRING CONNECTIONS TO BE INSTALLED IN ACCORDANCE WITH THE NEG FOR CLASS 1, DIV 2 GRPS. B, C, AND D. 14 (MAXIMUM AMBIENT TEMPERATURE 85 °C) HAZARDOUS LOCATIONS.
2. INSTALL A 1A, 600V/PV DIODE IN PARALLEL WITH DIGITAL SINKING OUTPUTS (1N4005 - P/NM P/N 36-16-1002).
3. USE TWO CONDUCTOR CABLE WITH FOIL SHIELD AND DRAIN WIRE FOR MPU INPUT.
4. USE EIA RS485 SHIELDED, TWISTED PAIR, 120 OHMS CHARACTERISTIC IMPEDANCE. INSTALL 120 OHMS TERMINATING RESISTOR ON FIRST AND LAST NODE ON RS-485/CANBUS NETWORK. ALL DEVICES MUST SHARE DC COMMON GROUND.
5. TO GROUND (IGNITION USE PILOT RELAY WITH 100 OHM, 2W SERIES RESISTOR TO GROUND).
6. RELAYS MUST BE HERMETICALLY SEALED RELAYS, CSA OR UL APPROVED FOR USE IN CL. 1, DIV. 2, GRPS. B, C, & D HAZARDOUS LOCATIONS.
7. NON-INCENDIVE FIELD WIRING CHARACTERISTICS:
 VOC = 16 VDC
 ISC = 10.8 mA
 Cmax = 0.2 uF
 Lmax = 100 mH

54	53	52	51	50	49	48	47
46	45	44	43	42	41	40	39
38	37	36	35	34	33	32	31
30	29	28	27	26	25	24	23
22	21	20	19	18	17	16	15
14	13	12	11	10	9	8	7
6	5	4	3	2	1	0	

SCREW TORQUE
 0.37 - 0.44 lbs/ft (0.5 - 0.6 Nm)

WIRE GAUGE
 12 - 24 AWG

STRIPPING LENGTH
 932 in. (mm)

WARNING - EXPLOSION HAZARD - DO NOT DISCONNECT EQUIPMENT UNLESS POWER HAS BEEN SWITCHED OFF OR THE AREA IS KNOWN TO BE NON-HAZARDOUS. AVERTISSEMENT - RISQUE D'EXPLOSION - AVANT DE DECONNECTER L'EQUIPEMENT, COUPER LE COURANT OU S'ASSURER QUE L'EMPLACEMENT EST DESIGNÉ NON DANGEREUX.

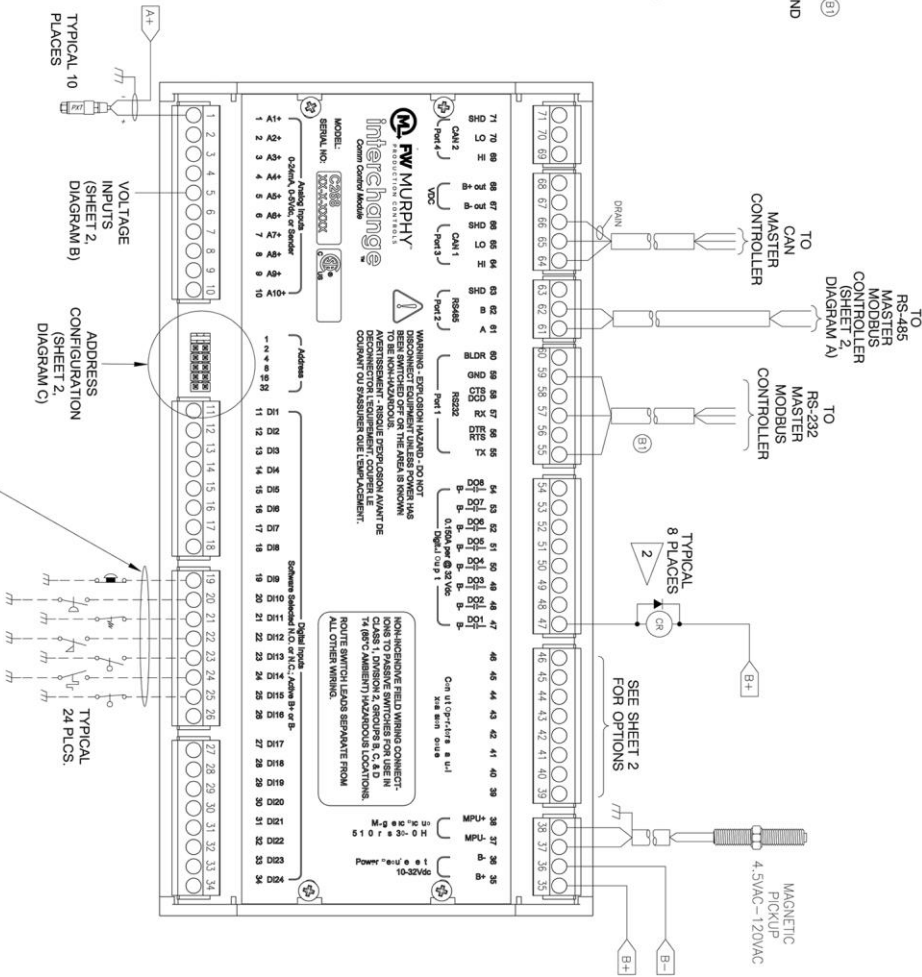
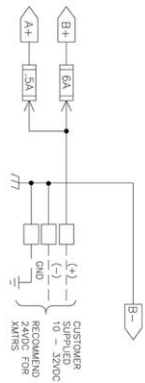

NON-INCENDIVE FIELD WIRING CONNECTIONS TO GENERAL PURPOSE ENCLOSURE PASSIVE MECHANICAL SWITCHES OR MURPHY SOLID STATE SWITCH DEVICES APPROVED FOR USE IN CL. 1, DIV. 2 GRPS. B, C, AND D HAZARDOUS LOCATIONS. ROUTE SWITCH LEADS SEPARATE FROM ALL OTHER WIRING.

DRAWING NO. SHEET 2 OF 2
 50-08-0054

SIZE REV.
 C B1

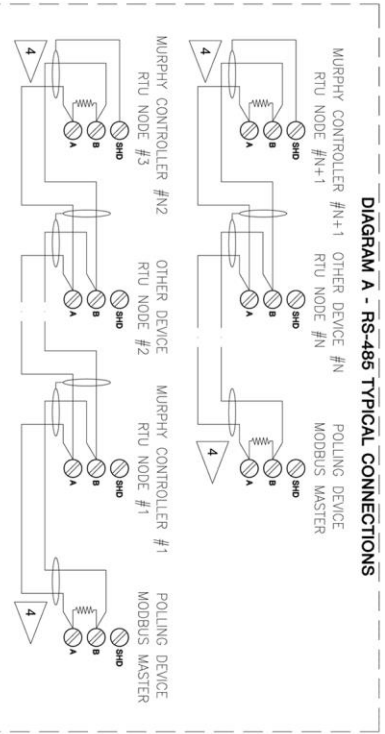

DIAGRAM B - TYPICAL VOLTAGE INPUT WIRING

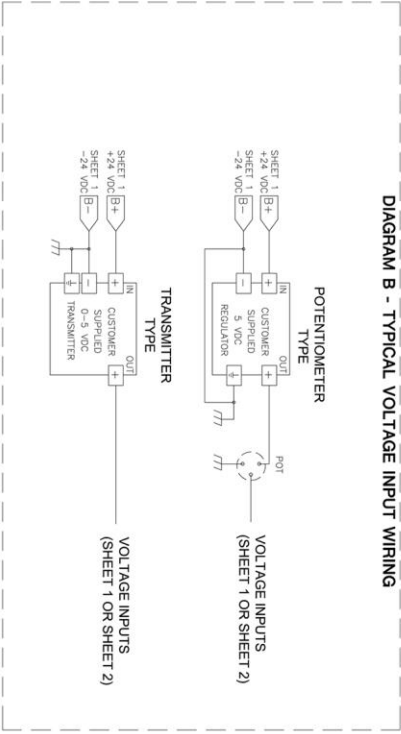
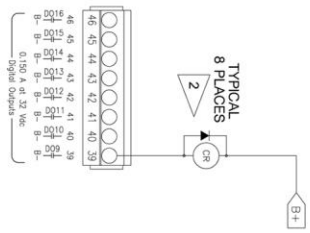
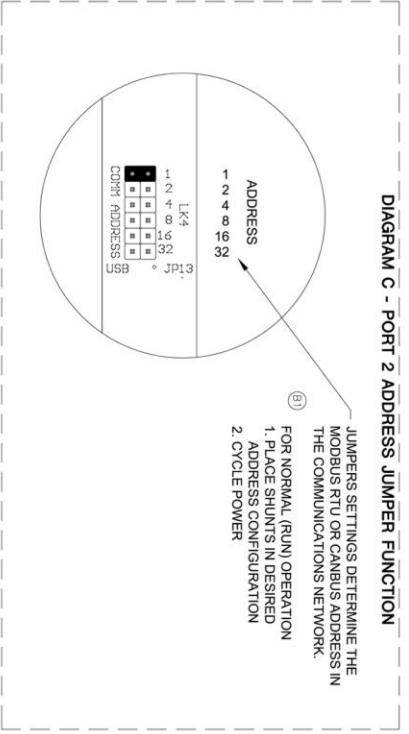
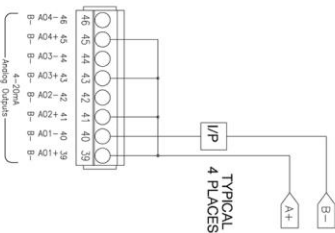

DIAGRAM C - PORT 2 ADDRESS JUMPER FUNCTION



MX5-D DIGITAL OUTPUT DAUGHTER BOARD



MX5-A ANALOG OUTPUT DAUGHTER BOARD

DRAWING NO.	SHEET 2 OF 2	SIZE	REV.
50-08-0054		C	B1

MX5 Jumper Configuration

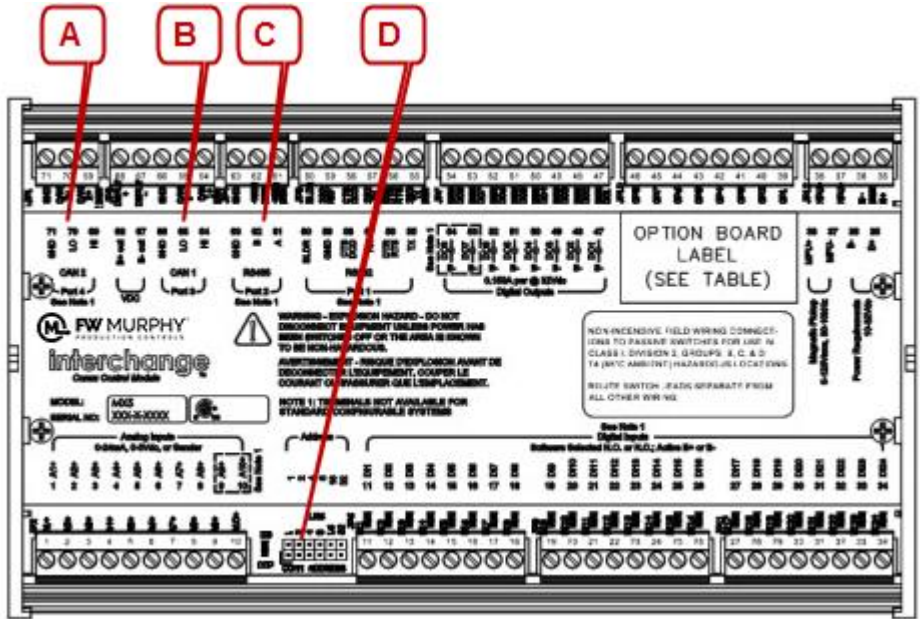

A CANbus: Communication Link to Main I/O Module

- LK2 and LK4:** This jumper provides a termination resistor for the CAN communication chain. This jumper must be in place only when the I/O module is the last in the communication chain. See control panel drawings for designation. The cover of the MX5 must be removed to access this jumper link (LK2/LK4). CAN 2 is not used. CAN 1 is used for data link for communication chain. (Refer to the **Communications** chapter in this document)

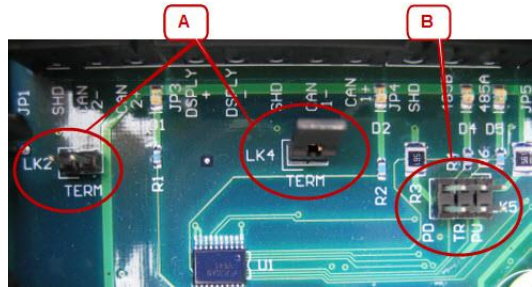

B RS485 Communication Port: Slave Comm. Port. (See Pictorial Above)

- LK5:** These jumpers provide a termination, pick-up and pull-down resistors for RS485 communication chain. The PU/PD jumpers should only be in one place on the communication chain. The TR jumper must be in place only when the I/O module is the last in the communication chain. See control panel drawings for designation. The cover of the MX5 must be removed to access this jumper link (LK5). (Refer to the **Communications** chapter in this document)

C Communication Address Select Shunts: Comm Address

- **LK6:** These jumpers allow designation for assigning a unique address to each MX5 that may be in the system. This allows the master controller to differentiate between the modules. For example, to name the controller address 5, place the shunts on LK1 and LK4. (Refer to the **Communications** chapter in this document)

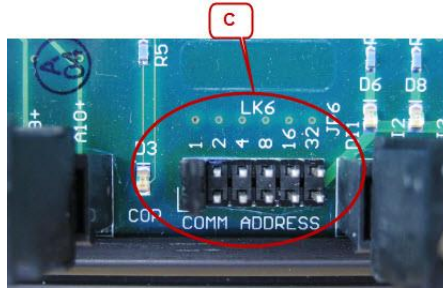

D Analog Input Select Shunts: Input Type

- **LK3:** These jumpers allow designation for assigning the type of analog signal type for each individual input. For a 0-24mA place jumper on middle and top pins. For a 0-5 VDC input, remove jumper.

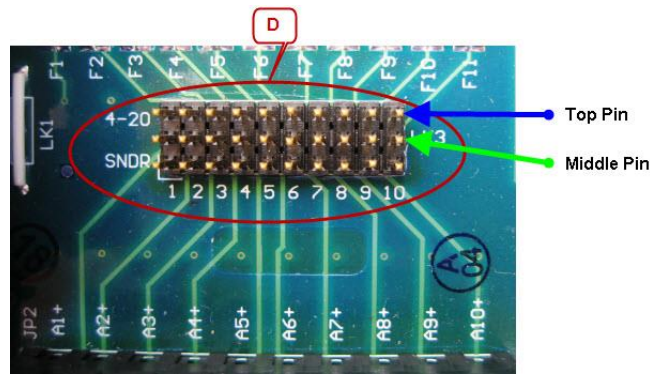

Communications

Physical Layer: The MX5 module features one asynchronous RS232 serial communication port, one asynchronous RS485 serial communication port and one CANbus 2.0B proprietary communication port.

RS232 Interconnect: The module is equipped with screw terminals called Port 1. This connection is typically used to poll the information for a specific module using twisted shielded cable suitable for RS232 networks. The simplest form of these networks are 3-wire, half-duplex, using RX terminal 57, TX terminal 55 and GND terminal 59. The TX terminal is the TRANSMIT DATA signal; the RX terminal is the RECEIVE DATA signal; and the GND is the COMMON GROUND signal for the communication line. These signal lines will take turns transmitting and receiving depending on the device using the RS232 network at any given instant. The MX5 also provides connections for CTS and DTR signals if required for 5-wire RS232 connections.

RS485 Interconnect: The module is equipped with screw terminals called Port 2. This connection is typically used to poll the information for a specific module using twisted shielded pair cable with 120 ohm impedance suitable for RS485 networks. These networks are 2-wire, half-duplex and feature an A terminal 61, B terminal 62 and SHD terminal 63 shielded ground connection. The A terminal is the + or non-inverting signal, and the B terminal is the – or inverting signal. These signal lines will take turns transmitting and receiving depending on the device using the RS485 network at any given instant.

Baud Rate: 9600 fixed (RS232/RS485)

Protocol: Modbus RTU. This is a binary communication protocol. All data will be contained in unsigned 16-bit Modbus Holding Registers (addressed starting at 40001). Following the Modbus RTU specification, the Most Significant Byte in a 16-bit word is broadcast first followed by the Least Significant Byte.

Refer to the Modbus RTU map provided in this manual for a detailed mapping of the available data and data scaling.

CANbus 2.0 B Interconnect: The module is equipped with screw terminals called Port 3. This connection is typically used to provide the interconnections between the main control module which polls the information for a specific module using twisted shielded pair cable with 120 ohm impedance suitable for CAN networks. This network protocol is proprietary CANbus and features a HI (CAN H) terminal 64, LO (CAN L) terminal 65 connection and SHD terminal 66 shielded ground connection.

Communication Address Select Shunts: A jumper shunt header is provided to assign a unique Modbus RTU and/or CANbus address to each expansion module that may be in the network. This allows the master controller to differentiate between the modules. Addressing is done in binary format, and each incrementing jumper increases the weight by a factor of 2.

For example, to name the controller address 5, place the shunts on LK1 and LK4. The sum makes 5 (4+1).

NOTE: RS485/RS232 Communication is 9600-N-8-1 for Address 0-31 and 9600-N-8-2 for Address 32-63. Registers start at 40,001.

Stop Bits: The module will respond with 1 stop bit for Modbus RTU addresses 1 through 31 and 2 stop bits for addresses 32 through 63. This maintains flexibility for systems requiring 2 stop bits.

Modbus RTU Polling Frequency: The module should be polled by the Modbus RTU Master with a delay of 30-50mS between packets, and typical response times will be < 100mS. This may vary depending on the amount of data requested on each module. Typical Modbus RTU timeout settings should be set to >= 400mS.

PC Connection: Most commercial PCs are equipped with one RS232 serial port in the form of a 9-pin D-Sub connection. If not, USB to RS232 adapters are also readily available. Testing for RS485 traffic can be done using a PC equipped with any Modbus RTU Master software and a serial interface converter that can convert RS232 traffic to RS485. The PC in this case would serve as the Modbus RTU master in lieu of an external controller.

MX5 Expansion Module - Modbus RTU Description

Modbus Register	Description	Read/Write	Range	Data Units	Definitions
40001 - 40020	Factory Use	R			
40021	Digital inputs 1-16	R	0 - 65535	each bit position is 1 input bitmapped where bit 0 = digital input 1	
40022	Digital inputs 17-24	R	0 - 255	each bit position is 1 input bitmapped where bit 0 = digital input 17	
40023	Raw count system voltage	R	0 - 1023	A/D count	0 = 0.0 VDC, 1023 = 5 VDC
40024	Raw count analog input 1	R	0 - 1023	A/D count	0 = 0.0 VDC, 1023 = 5 VDC
40025	Raw count analog input 2	R	0 - 1023	A/D count	0 = 0.0 VDC, 1023 = 5 VDC
40026	Raw count analog input 3	R	0 - 1023	A/D count	0 = 0.0 VDC, 1023 = 5 VDC
40027	Raw count analog input 4	R	0 - 1023	A/D count	0 = 0.0 VDC, 1023 = 5 VDC
40028	Raw count analog input 5	R	0 - 1023	A/D count	0 = 0.0 VDC, 1023 = 5 VDC
40029	Raw count analog input 6	R	0 - 1023	A/D count	0 = 0.0 VDC, 1023 = 5 VDC

Modbus Register	Description	Read/Write	Range	Data Units	Definitions
40030	Raw count analog input 7	R	0 - 1023	A/D count	0 = 0.0 VDC, 1023 = 5 VDC
40031	Raw count analog input 8	R	0 - 1023	A/D count	0 = 0.0 VDC, 1023 = 5 VDC
40032	Raw count analog input 9	R	0 - 1023	A/D count	0 = 0.0 VDC, 1023 = 5 VDC
40033	Raw count analog input 10	R	0 - 1023	A/D count	0 = 0.0 VDC, 1023 = 5 VDC
40034	Raw count analog input 11	R	0 - 4095	A/D count	Future Use
40035	Raw count analog input 12	R	0 - 4095	A/D count	Future Use
40036	Raw count analog input 13	R	0 - 4095	A/D count	Future Use
40037	Raw count analog input 14	R	0 - 4095	A/D count	Future Use
40038	Frequency input (hertz)	R	30 – 10,000	Hz	
40039	Modbus CTS	R	0 - 1	state of signal	
40040-40046	Factory Use	R			
40047	Analog output 1 signal	R/W	0 - 65535	Dependent on 40051	
40048	Analog output 2 signal	R/W	0 - 65535	Dependent on 40051	
40049	Analog output 3 signal	R/W	0 - 65535	Dependent on 40052	
40050	Analog output 4 signal	R/W	0 - 65535	Dependent on 40052	
40051	Analog outputs 1 & 2 type	R/W	0 - 3	0 = not used, 1 = 4 to 20 mA, 2 = 0 to 20 mA, 3 = 0 to 24 mA	
40052	Analog outputs 3 & 4 type	R/W	0 - 3	0 = not used, 1 = 4 to 20 mA, 2 = 0 to 20 mA, 3 = 0 to 24 mA	
40053	RTC Time - seconds	R	0 - 59		
40054	RTC Time - minutes	R/W	0 - 59		
40055	RTC Time - hours	R/W	0 - 23		
40056	RTC Day of week	R/W	`1 - 7		
40057	RTC Date - day	R/W	`1 - 31		
40058	RTC Date - month	R/W	`1 - 12		
40059	RTC Date - year	R/W	2000 - 3000		
40060	Clock set enable	R/W	0 - 1	1 = set above values into the realtime clock	
40061	Digital outputs 1-16	R/W	0 - 65535	each bit position is 1 input, bitmapped where bit 0 = digital output 1	upper 8 bits are for optional digital output daughter card
40062	Modbus DTR	R/W	0 - 1	set state of signal	
40063	Digital output 1-16 status on power-up	R/W	0 - 65535	each bit position is 1 output	upper 8 bits are for optional digital output daughter card
40064	Digital output 1-16 status on comm. failure	R/W	0 - 65535	each bit position is 1 output	upper 8 bits are for optional digital output daughter card
40065	Analog output 1 status on power-up	R/W	0 - 65535		
40066	Analog output 2 status on power-up	R/W	0 - 65535		
40067	Analog output 3 status on power-up	R/W	0 - 65535		
40068	Analog output 4 status on power-up	R/W	0 - 65535		
40069	Analog output 1 status on comm. failure	R/W	0 - 65535		
40070	Analog output 2 status on comm. failure	R/W	0 - 65535		

Modbus Register	Description	Read/Write	Range	Data Units	Definitions
40071	Analog output 3 status on comm. failure	R/W	0 - 65535		
40072	Analog output 4 status on comm. failure	R/W	0 - 65535		
40073	Communication timeout	R/W	0 – 65535	time in seconds	
40074 - 40077	Factory Use	R			

Register 40001 Value Description

Register 40,001 is a read-only register. This register holds the model number of the hardware. If you are using multiple Comm modules, it is sometimes helpful to confirm that you are communicating with the expected module type. In this case, it will return 268.

Register 40021 Value Description

Register 40,021 is a read-only register. The values returned in these registers are signed 16-bit data assigned to digital inputs 1-16. The channel's bit position is 1 input bitmapped where bit 0 = digital input 1.

Register 40022 Value Description

Register 40,022 is a read-only register. The values returned in these registers are signed 8-bit data, assigned to digital inputs 17-24. The channel's bit position is 1 input bitmapped where bit 0 = digital input 1. The additional upper bits for digital inputs 17-24 will remain at 0 and serve as padding to make a proper 16-bit word to comply with Modbus RTU specifications.

Register 40024 – 40033 Value Description

Registers 40,024 – 40,033 are read-only registers. The values returned in these registers are raw data counts for analog inputs from 0-1023 (0-5VDC). A typical 0-5VDC data count would be 0-1023 and a typical 4-20mA data count would be 181-904.

Register 40038 Value Description

Register 40,038 is a read-only register. This register displays the readings of the frequency input (magnetic pickup) in hertz (Hz).

Register 40047 – 40050 Value Description (MX5-A ONLY)

Registers 40,047 – 40,050 are read/write registers. The values returned in these registers are signed 16-bit data, assigned to analog outputs. These values are dependent on the setting of registers 40051 and 40052.

Register 40051 – 40052 Value Description (MX5-A ONLY)

Registers 40,051 – 40,052 are read/write registers. This will allow you to configure what type of signal is provided for analog outputs. Use the list below to determine what value you should write based on the sensor installed. Register 40051 establishes Analog Outputs 1-2, 40052 establishes Analog Outputs 3-4.

- 0 – Not Used
- 1 – 4-20mA
- 2 – 0-20mA
- 3 – 0-24mA

Register 40061 Value Description

Register 40,061 is a read/write register. The values returned in these registers are signed 16-bit data assigned to digital outputs. The channel's bit position is 1 input bitmapped where bit 0 = digital output 1. The upper 8-bits are reserved for the MX5-D. The lower bits are for the digital outputs for all models (MX5, MX5-A, MX5-D).

In order to consistently bring you the highest quality, full-featured products, we reserve the right to change our specifications and designs at any time. FW MURPHY product names and the FW MURPHY logo are proprietary trademarks. This document, including textual matter and illustrations, is copyright protected with all rights reserved. (c) 2019 FW MURPHY. A copy of our typical warranty may be viewed or printed by going to www.fwmurphy.com/warranty.

FW MURPHY PRODUCTION CONTROLS

SALES, SERVICES & ACCOUNTING
4646 S. HARVARD AVE.
TULSA, OK 74135

CONTROL SYSTEMS & SERVICES
105 RANDON DYER ROAD
ROSENBERG, TX 77471

MANUFACTURING
5757 FARINON DRIVE
SAN ANTONIO, TX 78249

DOMESTIC SALES & SUPPORT

FW MURPHY PRODUCTS
PHONE: 918 957 1000
EMAIL: INFO@FWMURPHY.COM
WWW.FWMURPHY.COM

FW MURPHY CONTROL SYSTEMS & SERVICES
PHONE: 281 633 4500
EMAIL: CSS-SOLUTIONS@FWMURPHY.COM

INTERNATIONAL SALES & SUPPORT

CHINA
PHONE: +86 571 8788 6060
EMAIL: INTERNATIONAL@FWMURPHY.COM

LATIN AMERICA & CARIBBEAN
PHONE: +1 918 770 8775
EMAIL: INTERNATIONAL@FWMURPHY.COM

SOUTH KOREA
PHONE: +82 70 7951 4100
EMAIL: INTERNATIONAL@FWMURPHY.COM



FM 668576 (San Antonio, TX - USA)
FM 668933 (Rosenberg, TX - USA)



FM 523851 (China) *TS 589322 (China)*