

# MARK III Series Digital Tattletale® Annunciator Installation and Operation Manual

Models: MARK III-N and MARK III-12/24



Please read the following information before installing. A visual inspection of this product for damage during shipping is recommended before mounting. This installation manual is intended for all MARK III Series models. It is your responsibility to have a qualified technician install the MARK III.

## GENERAL INFORMATION

### WARNING

BEFORE BEGINNING INSTALLATION OF THIS MURPHY PRODUCT

- ✓ Disconnect all electrical power to the machine.
- ✓ Make sure the machine cannot operate during installation.
- ✓ Follow all safety warnings of the machine manufacturer.
- ✓ Read and follow all installation instructions.



NRTL/C\*

Patent Numbers  
 4246493 and  
 4336463

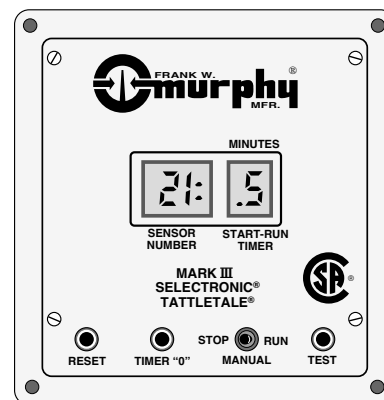

### Description

The MARK III Series is a solid-state fault annunciator and shutdown control system designed to protect engines and associated equipment. It accepts 32 normally open and/or normally closed sensors inputs. Fault conditions from the sensor inputs are annunciated on a Liquid Crystal Display. A selectable (0-9 minutes) Start-Run timer is included for use during start-up.

The MARK III provides for both, closing of a fuel valve and for grounding of the ignition for shutdown. A 2-3 second time delay in grounding the ignition after fuel valve closure is included. Built-in Test mode is included for sensor circuit testing without shutting down. On-board power supply and backup battery are included to retain a fault display after shutdown.

The MARK III is powered from a negative ground CD ignition or 12 or 24 VDC. Ignition Monitoring and Annunciation feature is used to monitor low ignition voltage (voltage drops below 75 VDC approx.), or for ignition failure.

Three Class "C" lockouts, four Class "C" lockouts, Remote Lockout, or Remote Reset options are also available (see descriptions on page 3).

## Suitable for Class I, Division 2, Group D Hazardous Locations.



**WARNING:** We do NOT recommend the use of switches having contacts immersed in oil. Because the MARK III Series operates on low voltage, the oil may act as an insulator between the contacts.

The MARK III includes a BCD Port, D-Sub type (7 bit BCD code) for interfacing with micro-controllers.

Two models are available:

**MARK III-N:** for negative ground CD ignitions systems.

**MARK III-12/24:** for 12 VDC or 24 VDC systems.

\* When installed per Murphy Drawings: HA14227 and HA14228. Contact the factory for more details.

## MOUNTING THE UNIT

The MARK III Series module is designed to be mounted within a weather-proof enclosure. A 5-1/2 in. (140 mm) square hole, and four (4) 3/16 in.

(5 mm) diameter screw holes are needed (see drawing below). Insert the unit from the front side of the enclosure and secure it with the mounting screws.

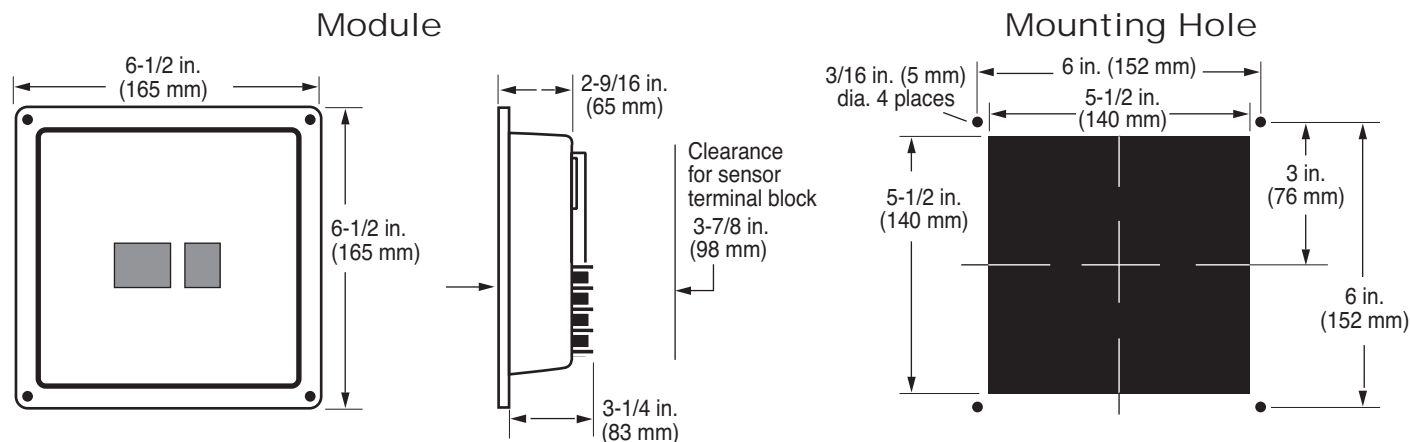

# TYPICAL WIRING DIAGRAMS

**WARNINGS:** For hazardous application requirements, the MARK III Series must be installed in accordance with the National Electrical Code (NEC) Class I, Div. 2, Gp. D specifications, and per Murphy drawings HA14227 and HA14228. Route sensor leads in conduit separate from all other wiring. Do NOT apply voltage to any annunciator sensor input terminals. To wire the MARK III Series models refer to the typical wiring diagrams, below .

## MARK III-N Module (Back View)

(For use in Class I, Div. 2 Gp. D Hazardous Locations)

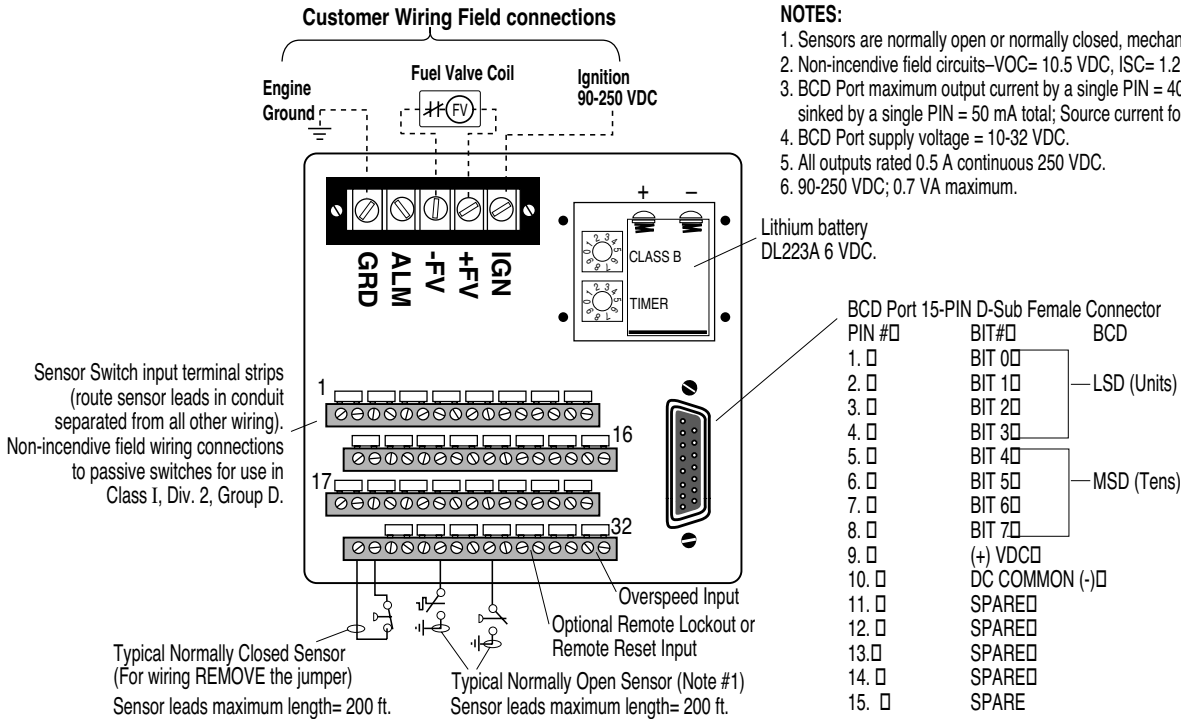

## MARK III-12/24 Module (Back View)

(For use in Class I, Div. 2 Gp. D Hazardous Locations)

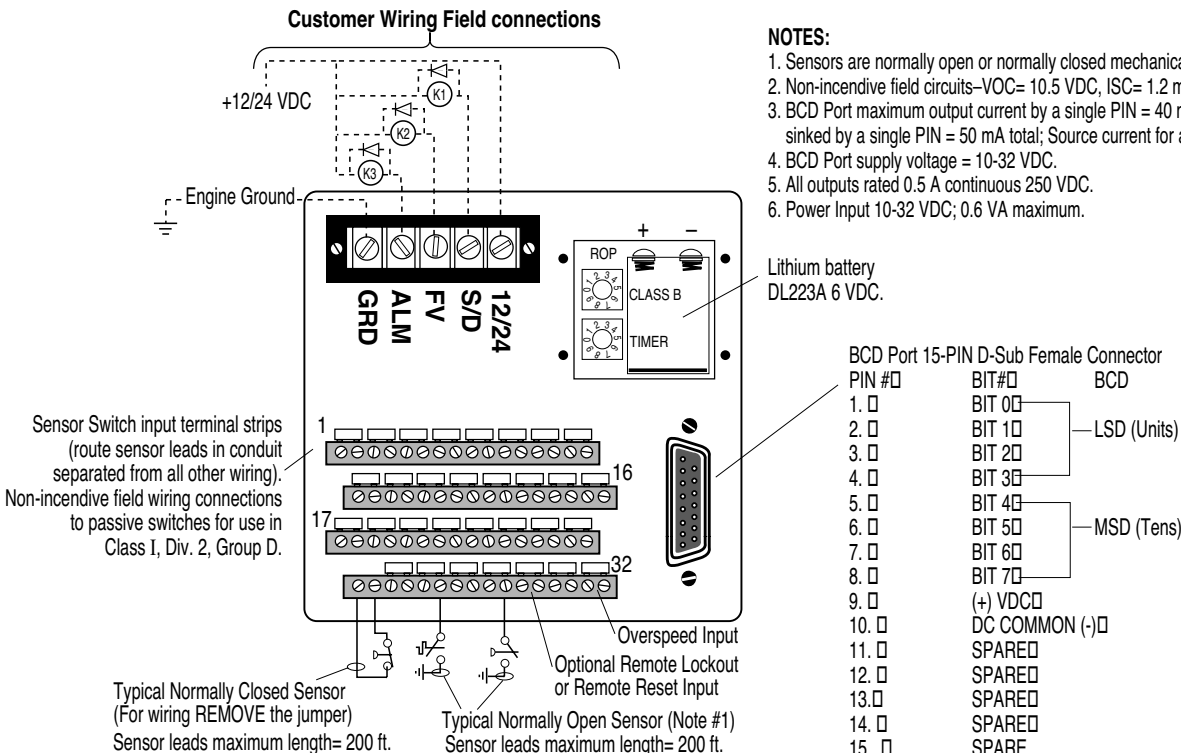

## CONTROLS AND INDICATORS DESCRIPTION

**The Module** monitors 32 input sensors. Any tripped sensor or panel stop is detected within 0.75 seconds of tripping. A Liquid Crystal Display indicates appropriate sensor number in the left two digits. The lockout timer countdown (in minutes) is displayed in the right window. A single flashing dot (.) in the right window, with the TEST button depressed indicates battery condition.

**Power and Control Inputs/Outputs** are interconnected from the power source and loads to the 5-point terminal block (on the back of the module).

**Sensor Inputs and Terminals:** 32 pairs of screw type connections each with a jumper, are connected to the back of the module. Sensors 1 thru 32 are dry contact, Class "A" sensors (always armed for shutdown). Input 31 is for emergency shutdown. Input 32 is for overspeed monitoring. Input 9 is locked out for 20 seconds during start-up unless selected as Class "B" (if selected as Class "B" the lock out time is set by the Start-Run timer).

**Class "B" Selector Switch:** Inputs 1 thru 9 can be field-selected as Class "B" sensors (see **Selecting Class "B" Sensors** on page 4).

**-C3 Three Class "C" Lockouts:** Inputs 28, 29, and 30 can be used as Class "C" lockouts. A Class "C" lockout must be cleared for 2 seconds before the sensor is armed.

**-C4 Four Class "C" Lockouts:** Inputs 27, 28, 29, and 30 can be used as Class "C" lockouts. Class "C" lockouts must be cleared for 2 seconds before sensors are armed.

**-RL Remote Lockout:** Input 30 can be used as remote lockout. A Closed switch across sensor 30 terminals inhibits the Class "B" lockout timer.

**-RR Remote Reset:** Input 30 can be used as remote reset. A Closed switch across sensor 30 terminals will reset a fault condition. The reset button on the Mark III operates normally allowing for reset of faults.

**Manual Stop/Run Switch:** During normal operation, place the switch in RUN. When placed in STOP, this switch shuts down the system from the panel by simulating a fault on sensor input 40 (manual stop). The number 40 will be displayed.

**Ignition Voltage Monitoring and Annunciation:** This feature is for sensing low ignition voltage (below 70 VDC approx.) or failure. Sensor number 41 is displayed.

**Reset Push Button:** Resets all tripped sensors, the display, alarm/shutdown outputs and the Start-Run Timer to full count. If any non-locked out sensor is operated, its number will be displayed when RESET is pressed.

**Timer "0" Push Button:** Zeroes the Start-Run Timer indicating a "0" in the Timer window. When in the START mode, pressing the Timer "0" button ends the Start-up and initiates the RUN mode, (if in TEST, it ends the test).

**Test Push Button (Press Reset then Test):** After start-up the TEST button sets the unit into TEST indicated by a colon symbol (:) in the left window. During TEST, faulted inputs are displayed as in normal operation, but system is **NOT** shut down (except for sensor 31, 32 and 40). The test period is timed and the system automati-

cally resets to "Run" when time expires. Pressing RESET during start up or Test periods, resets the start-run time to full count. If a sensor is left faulted in test and the time expires a shutdown occurs.

**Output Operation:** The MARK III-N +FV output is a non-switched output that supplies stored energy from an internal capacitor. -FV and ALM outputs are non-reversible switched outputs (switch off for normal operation, switched on for alarm/shutdown). If a fault is detected, the -FV and ALM turn on and after 3 seconds, the IGN switch turns on. MARK III-12/24 VDC S/D, FV, and ALM outputs are factory programmed to switch on for normal operation. Output operation can be reversed by removing the Reverse Output Tab (ROP), located at the upper left side of the backup battery. Refer to **Detail A**, on page 4 for location.

**Tripped Sensor:** When the MARK III senses a tripped sensor, it displays and retains the sensor number, then it sends a system shutdown signal. The remaining sensors are disabled until the RESET button is pressed.

**Start-Run Timer** (selectable 0–9 min., 1 min. increments): Allows the system to become fully operational without shutting down by run-related conditions. At start-up, Class "B" sensors are locked out until time expires. When time expires, the system is fully operational/running. If a Class "B" sensor is still tripped after time has expired, it will cause a system shutdown, displaying the faulted sensor. Remaining Class "A" inputs are functional during start-up, and will shut down the engine if tripped. Pressing Timer "0" forces the timer count to zero, ending the lockout.

**Start-Run Timer as Test Timer (Reset First):** When Start-Run timer is in TEST, a colon (:) is displayed in the sensor number window, the unit locks out the shutdowns and enables the sensors to be tripped/displayed individually, but inhibits shutdown due to tripped sensors until time expires. Press Reset for timer to restart at full count. TEST ends when timer counts to zero or if Timer "0" is used.

**BCD Port:** The BCD equivalent to the sensor number, displayed in the sensor Number window, is latched on to the BCD output port whenever the MARK III detects a fault. The output is reset to zero, when all tripped sensors are reset. To activate the BCD output, 10-32 VDC are required between pins 9 and 10 of the port D-sub connector. See page 2, MARK III (Back View), notes 3 and 4.

**Barrier for Non-intrinsically Safe Inputs:** The LCDT-ISB barrier converts 2 non-intrinsically safe, **normally open** inputs to intrinsically safe outputs. An internal terminal block provides connection for user circuits. A factory-installed cable, from output terminal block, provides intrinsically safe connection to the MARK III input terminals. Minimum input voltage for the barrier is 90 volts.

**IMPORTANT:** To use the MARK III with active sensors or non isolated relay contacts, an approved intrinsically safe barrier is required between the MARK III sensor input terminals and the sensors.

## SEQUENCE OF OPERATIONS

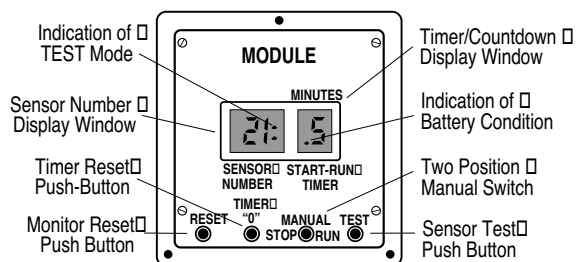

**NOTE:** Perform this operation with the unit properly installed and sensors cleared.

### Initially Faulted Sensor Check (before start-up).

Set Manual Stop-Run Switch to RUN, press RESET and observe Sensor Number window for faulted sensor indication (clear faulted sensors if needed).

### System Start-up (Set Manual Stop-Run Switch to RUN.)

Press RESET to clear any annunciated sensors and unground or enable the ignition for engine operation. Apply starting power to engine. At time out of the Start-Run Timer, all locked out sensors are set into service.

### Sensor Test (To verify that sensors are hooked up and working).

Press RESET to override shutdown while sensors are being tested. Press TEST and verify that the colon is in the display to indicate TEST mode, and that full count appears in Start-Run Timer display.

**NOTE:** Test ends when time expires; Press RESET for a full count.

### Testing the system sensors

Trip first sensor to be tested and verify that sensor number appears in Sensor Number window. Clear the sensor just tripped then press RESET. Verify that sensor number is cleared and that full count appears on window.

**NOTE:** The unit must be cleared after tripping a sensor, or the engine will shut down when the timer time expires.

Repeat the above procedure for each sensor. To end test, press Timer "0".

### System Shutdown

Set the Manual STOP/RUN switch to STOP and verify that the engine stops and manual stop (number 40) is displayed. **NOTE:** Manual stop number (40) and Sensor number (31) will override the TEST condition and shutdown the engine.

## SPECIFICATIONS

**Power Consumption:** 700  $\mu$ a, 100 VDC.

**Power Inputs (Operating Voltages):**

MARK III-N: 90-250 V, CD ignition negative ground.

MARK III-12/24: 12-24 VDC @ 4.7 W maximum including [2] two externally operated relays.

**Sensor Inputs:** MARK III accepts 32 sensor switches.

These can be either normally open or normally closed passive switches.

Inputs 1-32: Designated as Class "A" sensors.

Inputs 1-9: Can be selected as Class "B" sensor lockouts.

Inputs 28-30: When specified, dedicated as three Class "C" lockouts.

Inputs 27-30: When specified, dedicated as four Class "C" lockouts.

Input 30: When specified, dedicated as Remote Lockout or Remote Reset input.

Input 31: Overrides Test timer, (typically used for Remote Stop input).

Input 32: Overrides Test timer dedicated for overspeed sensing.

**Outputs (all models):** FET (Field Effect Transistor); 0.5 amp @ 250 V max.

**Operating Temperature:** -40 to 185°F (-40 to 85°C).

**Storage Temperature:** -40 to 302°F (-40 to 150°C).

**Case:** Anodized aluminum.

**Multiplexer Scan Rate:** Scans all 32 sensors in 0.75 seconds.

**Start-Run/Test Time:** Selectable from 0 thru 9 minutes (1 min. increments).

**Backup Power (all models):** On-board 6 VDC @ 1300 mAh, DL223A lithium.

**Shutdown Outputs:** Negative ground and 12/24 VDC versions:

FET (Field Effect Transistor); 0.5 amp @ 250 V max.

**Output Selections:**

- Ground Ignition immediately.
- Trip fuel valve, then ground ignition after a 2-3 seconds factory-set delay.

*Note:* MARK III-12/24 outputs switch "ON" for normal operation; output operation can be reversed by removing ROP tab (see Detail "A"; below).

**Sensor Terminal Block:** Four (4) Plug-in terminal(s) with screw type connections and factory installed jumper for each terminal.

## CLASS B SENSOR AND TIMER SELECTION — BATTERY REPLACEMENT

### Selecting Class "B" Sensors

**1. Shutdown the system.**

2. Remove the battery cover located on the back of the MARK III module and locate the Class "B" selector switch, (Detail A).

3. Select the number of Class "B" sensors by rotating the selector switch to the desired number (Detail B). Factory setting for this selector switch is "0".

Example: if the selector is rotated to 5, sensors 1 thru 5 will be disabled at start-up.

4. When finished replace battery cover or proceed to select the Start Run time.

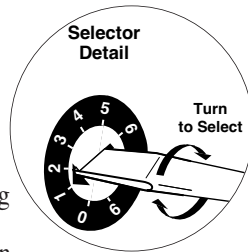

Detail B

Detail A

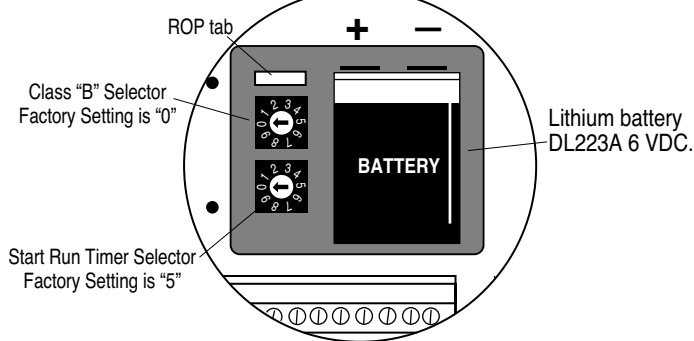

### Selecting the Time for the Start Run Timer

**1. Shutdown the system.**

2. Locate the Start Run Timer selector switch (Detail A).

3. Select the allowable amount of time for the system to become fully operational without shutting down by run-related conditions. (Detail B). Selectable from 0 thru 9 minutes, in 1 minute increments. Factory setting for this timer is "5".

### Replacing the Battery

**1. Shutdown the system.**

2. Remove battery cover located on the back of the MARK III module and locate the battery (Detail A). All MARK III models require a DL223A, 6.0 VDC, lithium battery.

3. To check the battery, hold down TEST push button and check Start-Run Timer display. A blinking decimal point visible in the display indicates low battery (Detail C).

4. Replace the battery. Observe polarity.

5. Replace the battery cover. Check for accidentally removed wires.

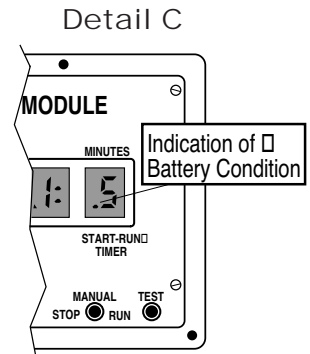

### Warranty

A limited warranty on materials and workmanship is given with this FW Murphy product.

A copy of the warranty may be viewed or printed by going to [www.fwmurphy.com/support/warranty.htm](http://www.fwmurphy.com/support/warranty.htm)



[www.fwmurphy.com](http://www.fwmurphy.com)

918.317.4100 Email: [sales@fwmurphy.com](mailto:sales@fwmurphy.com)

MURPHY, the Murphy logo, and Tattletale® are registered and/or common law trademarks of Murphy Industries, Inc. This document, including textual matter and illustrations, is copyright protected by Murphy Industries, Inc., with all rights reserved. (c) 2006 Murphy Industries, Inc. Other third party product or trade names referenced herein are the property of their respective owners and are used for identification purposes only.