

# Pneumatic Valves for Fuel Gas Shutoff

## Models M2582-P and M5180-P

The MS582-P and M5180-P are pneumatically controlled fuel shutoff valves that open and close automatically or semi-automatically. The pneumatic control pressure can be air, oil or gas. A manual lever aids in opening the valve when control pressure is insufficient. A gas escape vent, when properly vented and maintained, releases trapped gas from the valve after shutoff. Basic operation is:

**Automatic:** As the control pressure/vacuum increase the valve will open. When the control pressure/vacuum decreases, the valve will close.

**Semi-Automatic:** If the control pressure/vacuum is too low and the valve does not open automatically, it can be opened manually by lifting the built-in lever arm and setting the latch. The latch resets automatically when control pressure rises enough to release it.

M2582-P is for 1-inch (25 mm) gas lines. It automatically opens at 5 psi (35kPa) [0.34 bar] and fully opens the seat at 15 psi (103 kPa) [1.02 bar]. The valve can be manually opened with the lever and latch against inlet pressure of 80 psi (552 kPa) [5.52 bar]. The latch will release after pilot pressure reaches 11 psi (17kPa) [.17 bar].

M5180-P is for 2-inch (52 mm) gas lines. It automatically opens at 5 psi (35kPa) [0.34 bar] and fully opens the seat at 15 psi (21 kPa) [.21 bar]. The valve can be manually opened with the lever and latch against inlet pressure of 100 psi (689 kPa) [6.89 bar]. The latch will release after pilot pressure reaches 11 psi (17kPa) [.17 bar].



## Dimensions

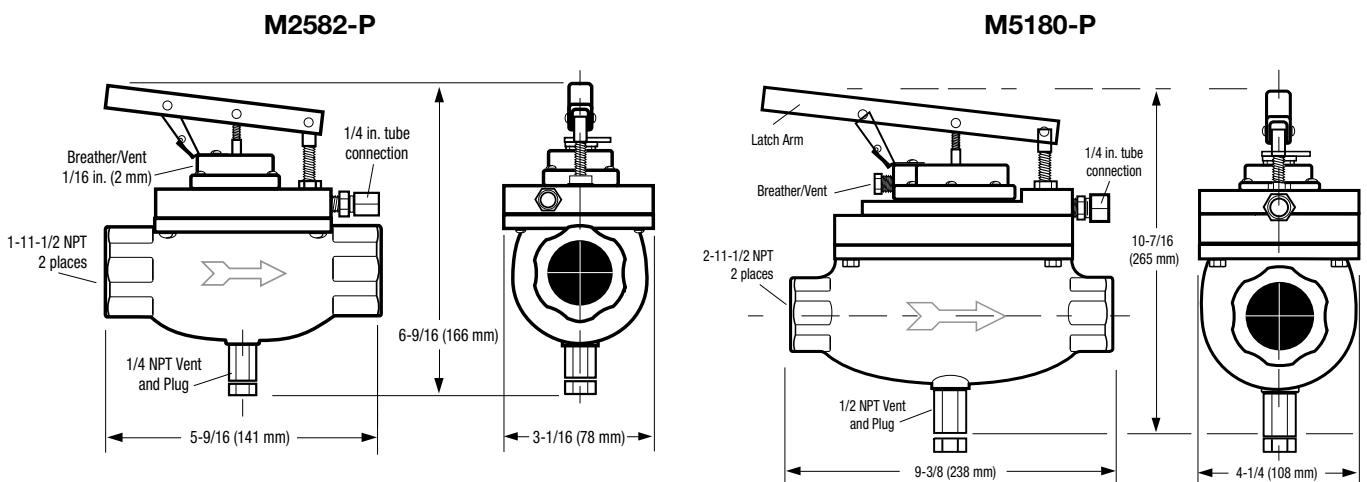

**M2582-P / M5180-P:** Latch Arm, thumb operated opening latch requires 2.5 psi, (0.17 bar) to release cocking latch.

**M2582-P:** Control pressure fitting, 1/4 in. (6 mm) tube connection; 15 psi. (103 kPa) [0.21 bar] min., 75 psi. (517 kPa) [5.17 bar] max.

**M5180-P:** Control pressure fitting, 1/4 in. (6 mm) tube connection; 15 psi. (103 kPa) [0.21 bar] min., 80 psi. (552 kPa) [5.52 bar] max.

**M5180-P:** Breather vent fitting can be swapped with the control pressure fitting to convert to vacuum control.

# M2582-P Flow Characteristics Laboratory Test

# Specifications

**Valve body:** Sandcast aluminum (alodined for corrosion resistance). Optional steel body available on M5180-P models only.

**Valve seat:** Buna-N

**Valve Inlet Pressure (maximum):**

- M2582-P: 80 psi (552 kPa) [5.52 bar]
- M5180-P: 100 psi (689 kPa) [6.89 bar]

**Parts exposed to gas line flow:**

- M2582-P:
- Aluminum
  - Buna-N
  - 302, 303 and 17-7 PH stainless steel
- M5180-P:
- Aluminum (steel optional)
  - Buna-N
  - 302, 303, 304 and 416 stainless steel

**Control diaphragm:** Flexweave polyester fabric and Buna-N elastomer

**Control pressure (maximum):**

- M2582-P: 75 psi (517 kPa) [2.55 bar]
- M5180-P: 80 psi (552 kPa) [5.52 bar]

**Shipping Weights:**

- M2582-P: 5 lbs 10 oz (2.55 kg)
- M5180-P: 9 lbs 2 oz (4.16 kg)
- With steel body option: 25 lbs (11.34 kg)

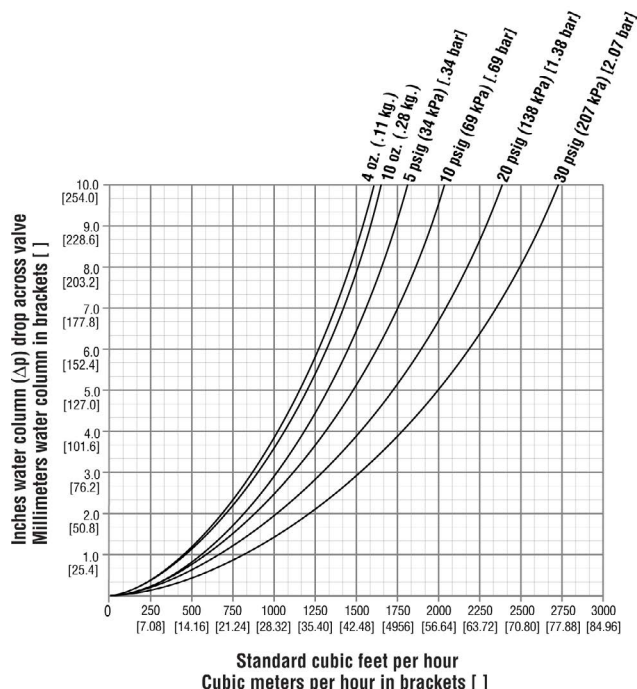

## How To Order

Options listed below. All configurations may not be available. Call your sales representative or FW Murphy for more information.

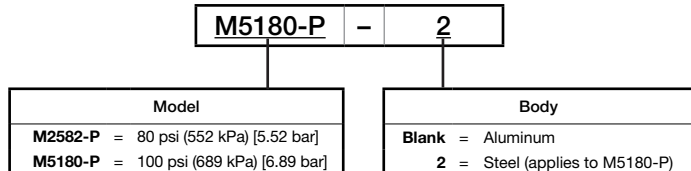

Approximate Shipping Weight	
Model	Weight
M2582-P	5 lbs 10 oz (2.55 kg)
M5180-P	9 lbs 2 oz (4.16 kg)

Part Number	Description	Notes
55000148	Latching Handle Assembly	M2582-P Service Parts
55000147	Stem & Seat Assembly	
55000150	Top Works Complete Valve Less Body & Vent Repair Kit	
55000143	Vent Bushing Assembly Kit	
55000184	Diaphragm Assembly Kit	
55000154	Latching Handle Assembly	M5180-P Service Parts
55000155	Top Works Complete Valve Less Body & Vent Repair Kit	
55000132	Vent Bushing Assembly Kit	
55000153	Diaphragm Assembly Kit	