

M-VIEW™ Series CCP Protocol Module



- CONFIGURED USING M-VIEW DESIGNER 3.1
- DIGITALLY ISOLATED CCP PORT CAPABLE OF COMMUNICATING WITH ANY CCP PROTOCOL DEVICE
- POWERED AND CONFIGURED FROM M-VIEW HOST DEVICE
- BUILT-IN TERMINATION RESISTOR SELECTABLE THROUGH A SWITCH



FOR USE IN HAZARDOUS LOCATIONS:
 Class I, Division 2, Groups A, B, C, and D
 T4



II 3 G Ex nA IIC T4 Gc
 -40°C ≤ T_{AMB} ≤ 75°C
 DEMKO 14 ATEX 1387X
 IECEx UL 15.0035X



GENERAL DESCRIPTION

The MV-CCP is a CCP protocol communication module designed for use with the FW Murphy Engine Integrated Control System (EICS). The CCP protocol is a proprietary protocol layer operating over CAN to the EICS. The module provides the M-VIEW host device a CCP protocol communications port. It is built with digital isolation to protect the M-VIEW host device from the CCP protocol bus and vice versa. The MV-CCP module has a termination resistor built-in, and is selectable through a switch. The connector is pluggable for easy removal of the MV-CCP module from the CCP protocol bus, without disturbing communications with other devices on the bus.

The modules connect and communicate via proprietary USB connection to the various M-VIEW devices. The M-VIEW devices, equipped with serial ports as well as Ethernet port(s), allow the system to share data with PCs, PLCs and SCADA systems. The maximum number of modules varies for each M-VIEW device, see specific model for details. Remove power from the host device before installing or replacing any modules.

CONFIGURATION

The M-VIEW device is configured with Windows® compatible M-VIEW DESIGNER 3.1 software. The software is an easy to use, graphical interface which provides a means of configuration and commissioning of new systems, as well as routine module re-calibration.

SAFETY SUMMARY

All safety related regulations, local codes and instructions that appear in this literature or on equipment must be observed to ensure personal safety and to prevent damage to either the instrument or equipment connected to it. If equipment is used in a manner not specified by the manufacturer, the protection provided by the equipment may be impaired.

Do not use this unit to directly command motors, valves, or other actuators not equipped with safeguards. To do so can be potentially harmful to persons or equipment in the event of a fault to the unit.



CAUTION: Risk of Danger.
 Read complete instructions prior to installation and operation of the unit.



WARNING - EXPLOSION HAZARD - DO NOT DISCONNECT EQUIPMENT UNLESS POWER HAS BEEN SWITCHED OFF OR AREA IS KNOWN TO BE NON-HAZARDOUS.



WARNING - EXPLOSION HAZARD - SUBSTITUTION OF COMPONENTS MAY IMPAIR SUITABILITY FOR CLASS I, DIVISION 2.

DIMENSIONS In inches (mm)

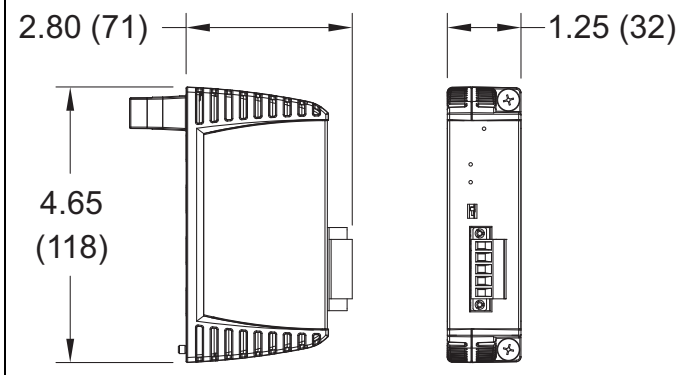

ORDERING INFORMATION

DESCRIPTION	PART NUMBER
M-VIEW Module, CCP protocol Interface	50704943

A listing of the entire M-VIEW family of products and accessories can be found at www.fwmurphy.com.

SPECIFICATIONS

- POWER:** Power will be supplied by the M-VIEW host device. Some modules, depending on usage may consume high levels of power. This may limit the total number of modules that can be installed on a single M-VIEW host. Check the M-VIEW module and M-VIEW host data sheets for specific usage and power requirements.
MV-CCP Max Power: 1.2 W

- COMMUNICATIONS:**

CAN Protocol Port: The CAN protocol port has format and baud rates that are software programmable up to 1M baud and is digitally isolated. 124 ohm, 1W termination is provided through a switch.

Isolation from MV-CCP Communication ports to M-VIEW host device: 1000 VDC for 1 minute.

- ENVIRONMENTAL CONDITIONS:**

Operating Temperature Range: -40 to 75 °C, or lowest range among equipment used in your M-VIEW system. Consult the user manual for further details.

Storage Temperature Range: -40 to +85 °C

Operating and Storage Humidity: 85% max. relative humidity, non-condensing

Altitude: Up to 2000 meters

- CERTIFICATIONS AND COMPLIANCES:**

CE Approved

EN 61326-1 Immunity to Industrial Locations

IEC/EN 61010-1

RoHS Compliant

ATEX Approved

Ⓜ II 3 G Ex nA IIC T4 Gc

DEMKO 14 ATEX 1387X

EN 60079-0, -15

IECEx Approved

Ex nA IIC T4 Gc

IECEx UL 15.0035X

IEC 60079-0, -15

UL Listed: File #E302106

UL Hazardous: File #E317425

ABS Type Approval for Shipboard Applications

- CONSTRUCTION:** Case body is all metal construction.
- CONNECTIONS:** Removable wire clamp screw terminal blocks
 Wire Gage: 28-14 AWG (0.32 mm - 1.63 mm) terminal gage wire
 Torque: 1.95-2.21 inch-lbs (0.22-0.25 N-m)
- MOUNTING:** Screws to host
- WEIGHT:** 6.9 oz (196 g)

Block Diagram for MV-CCP

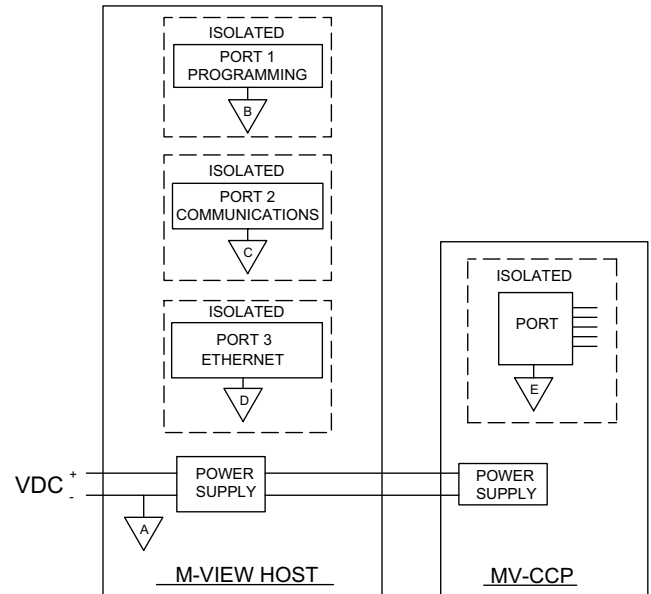

EMC INSTALLATION GUIDELINES

Although FW Murphy products are designed with a high degree of immunity to Electromagnetic Interference (EMI), proper installation and wiring methods must be followed to ensure compatibility in each application. The type of the electrical noise, source or coupling method into a unit may be different for various installations. Cable length, routing, and shield termination are very important and can mean the difference between a successful or troublesome installation. Listed are some EMI guidelines for a successful installation in an industrial environment.

- A unit should be mounted in a metal enclosure, which is properly connected to protective earth.
- Use shielded cables for all Signal and Control inputs. The shield connection should be made as short as possible. The connection point for the shield depends somewhat upon the application. Listed below are the recommended methods of connecting the shield, in order of their effectiveness.
 - Connect the shield to earth ground (protective earth) at one end where the unit is mounted.
 - Connect the shield to earth ground at both ends of the cable, usually when the noise source frequency is over 1 MHz.
- Never run Signal or Control cables in the same conduit or raceway with AC power lines, conductors, feeding motors, solenoids, SCR controls, and heaters, etc. The cables should be run through metal conduit that is properly grounded. This is especially useful in applications where cable runs are long and portable two-way radios are used in close proximity or if the installation is near a commercial radio transmitter. Also, Signal or Control cables within an enclosure should be routed as far away as possible from contactors, control relays, transformers, and other noisy components.

- Long cable runs are more susceptible to EMI pickup than short cable runs.
- In extremely high EMI environments, the use of external EMI suppression devices such as Ferrite Suppression Cores for signal and control cables is effective.

Contact FW Murphy Technical Support for recommendation for your application.

- To protect relay contacts that control inductive loads and to minimize radiated and conducted noise (EMI), some type of contact protection network is normally installed across the load, the contacts or both. The most effective location is across the load.
 - Using a snubber, which is a resistor-capacitor (RC) network or metal oxide varistor (MOV) across an AC inductive load is very effective at reducing EMI and increasing relay contact life.
 - If a DC inductive load (such as a DC relay coil) is controlled by a transistor switch, care must be taken not to exceed the breakdown voltage of the transistor when the load is switched. One of the most effective ways is to place a diode across the inductive load. Most FW Murphy products with solid state outputs have internal zener diode protection. However external diode protection at the load is always a good design practice to limit EMI. Although the use of a snubber or varistor could be used.
- Care should be taken when connecting input and output devices to the instrument. When a separate input and output common is provided, they should not be mixed. Therefore a sensor common should NOT be connected to an output common. This would cause EMI on the sensitive input common, which could affect the instrument's operation.

HARDWARE INSTALLATION

The physical order of all installed modules must match the module's configured order in M-VIEW DESIGNER 3.1. Torque screws to 6.0 pound-force inch [96 ounce-force inch] (0.68 Nm).

WARNING: Disconnect all power to the unit before installing or removing modules.

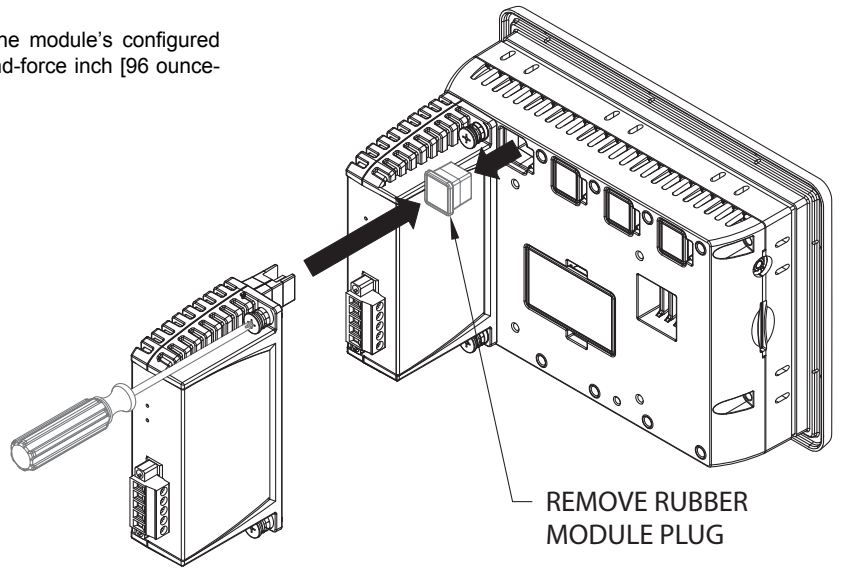

COMMUNICATING WITH THE MV-CCP MODULE

CONFIGURATION

Programming is done via M-VIEW™ DESIGNER 3.1 software, a Windows® compatible configuration interface. Please see the M-VIEW DESIGNER 3.1 User Manual for more information.

CCP PORT PROTOCOLS

The MV-CCP module has one CAN protocol port.

Figure 3. MV-CCP PORT PIN OUTS

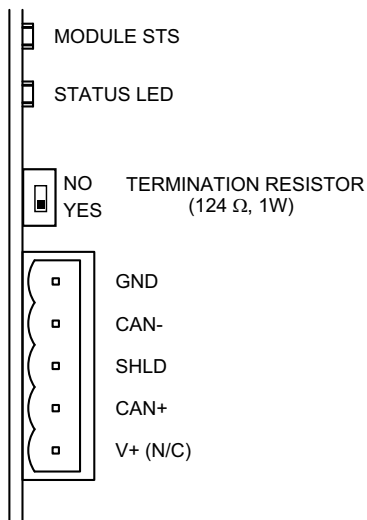

TERMINATION RESISTOR

An onboard termination resistor is selectable through a switch. The termination resistor is rated for 124Ω at 1W. If a different termination resistance is desired, slide the switch for no termination resistor. At this point you will be required to connect your own termination resistor between positions 2 and 4 of the five position connector.

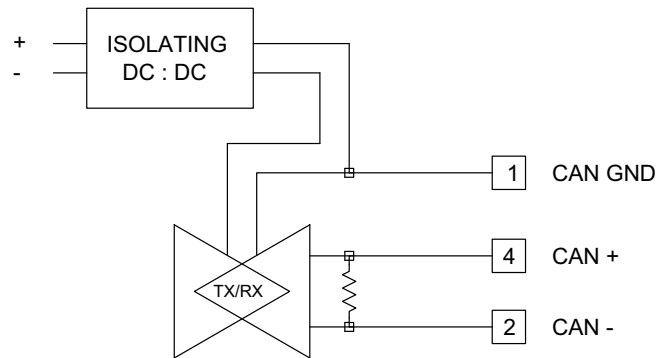

CAN GND

Position 1 of the pluggable connector provides a CAN ground connection. This terminal is isolated from the M-VIEW host device.

CAN-

Position 2 of the pluggable connector provides the CAN- bus line (active low). This terminal is isolated from the M-VIEW host device.

WARNING - EXPLOSION HAZARD - DO NOT CONNECT OR DISCONNECT CABLES WHILE POWER IS APPLIED UNLESS AREA IS KNOWN TO BE NON-HAZARDOUS.

SHLD (OPTIONAL CAN SHIELD)

Position 3 of the pluggable connector is provided for optional shield connections. This position is available only to tie shield wires together or to earth ground. There is no internal connection to earth ground. The SHLD position is not connected to any circuitry internal to the MV-CCP module or M-VIEW Host device.

CAN+

Position 4 of the pluggable connector provides the CAN+ bus line (active high). This terminal is isolated from the M-VIEW host device.

V+ (OPTIONAL 24 VDC)

Position 5 of the pluggable connector is provided for optional 24 VDC connections. This position is available only to tie 24 VDC wires together. The MV-CCP module neither provides 24 VDC power nor uses 24 VDC power through this connection. The V+ position is not connected to any circuitry internal to the MV-CCP module or M-VIEW Host device.

LEDs

MODULE STS – STATUS LED

The Status LED is a green/red LED that provides information regarding the state of the module. This includes indication of the various stages of the start-up routine (power-up), as well as any errors that may occur.

Startup Routine

Flashing Red	Module is currently running the boot loader and/or being flash upgraded by M-VIEW DESIGNER 3.1.
Green	Module performing normally.

Error States

Flashing Green	Module has lost communication with the Host.
----------------	--

STATUS LED

Green	MV-CCP module established communication with other CAN protocol devices (RUN) and is communicating normally.
Red	MV-CCP module failed to establish communications with other CAN protocol devices (ERROR).

FIRMWARE UPGRADE

The module's firmware is stored in flash memory so that software/hardware conflicts are avoided, and so features can be added in the future.

During a download, M-VIEW DESIGNER 3.1 compares its own library of firmware files with those stored in the module. If they do not match, M-VIEW DESIGNER 3.1 will download the necessary firmware.

M-VIEW TROUBLESHOOTING

If for any reason you have trouble operating, connecting, or simply have questions concerning your new M-VIEW unit, contact FW Murphy's technical support.

Phone: (918) 957-1000
 Email: techsupport@fwmurphy.com

Warranty - A limited warranty on materials and workmanship is given with this FW Murphy product. A copy of the warranty may be viewed or printed by going to <http://www.fwmurphy.com/warranty>

FW MURPHY PRODUCTION CONTROLS

SALES, SERVICES & ACCOUNTING
 4646 S. HARVARD AVE.
 TULSA, OK 74135

CONTROL SYSTEMS & SERVICES
 105 RANDON DYER ROAD
 ROSENBERG, TX 77471

MANUFACTURING
 5757 FARINON DRIVE
 SAN ANTONIO, TX 78249

DOMESTIC SALES & SUPPORT

FW MURPHY PRODUCTS
 PHONE: 918 957 1000
 EMAIL: INFO@FWMURPHY.COM
WWW.FWMURPHY.COM

FW MURPHY CONTROL SYSTEMS & SERVICES
 PHONE: 281 633 4500
 EMAIL: CSS-SOLUTIONS@FWMURPHY.COM

INTERNATIONAL SALES & SUPPORT

CHINA
 PHONE: +86 571 8788 6060
 EMAIL: INTERNATIONAL@FWMURPHY.COM

LATIN AMERICA & CARIBBEAN
 PHONE: +1 918 957 1000
 EMAIL: INTERNATIONAL@FWMURPHY.COM

SOUTH KOREA
 PHONE: +82 70 7951 4100
 EMAIL: INTERNATIONAL@FWMURPHY.COM



FM 668576 (San Antonio, TX - USA)
 FM 668933 (Rosenberg, TX - USA)



FM 523851 (China) TS 589322 (China)