



Centurion[™] - C5 Series Application Controller

Installation Manual

Warranty - A limited warranty on materials and workmanship is given with this FW Murphy product. A copy of the warranty may be viewed or printed by going to <http://www.fwmurphy.com/warranty>



**BEFORE BEGINNING INSTALLATION OF THIS FW MURPHY
PRODUCT:**

- Please read the following information before installing the Centurion controller. This installation information is intended for Centurion controller only.
- Visually inspect the product for any damage during shipping.
- Before proceeding, please visit our website and review our support documentation including Wiring the Murphy Way.
www.fwmurphy.com/uploaded/WIR_Murphy_Way.pdf
- Disconnect all power and be sure machine is inoperative before beginning installation.
- Installation is to be done only by a qualified technician of the Responsible Body.
- Observe all Warnings and Cautions at each section in these instructions.
- Device shall be wired in accordance with NEC, CEC or other local code, as applicable.
- Please contact FW Murphy immediately if you have any questions.

For Class I, Division 2:

THIS EQUIPMENT IS AN OPEN-TYPE DEVICE AND IS MEANT TO BE INSTALLED IN AN ENCLOSURE SUITABLE FOR THE ENVIRONMENT SUCH THAT THE EQUIPMENT IS ONLY ACCESSIBLE WITH THE USE OF A TOOL.

THIS EQUIPMENT IS SUITABLE FOR USE IN CLASS I, DIVISION 2, GROUPS A, B, C AND D OR NON-HAZARDOUS LOCATIONS ONLY.

WARNING – EXPLOSION HAZARD – DO NOT DISCONNECT EQUIPMENT UNLESS POWER HAS BEEN REMOVED OR THE AREA IS KNOWN TO BE NON-HAZARDOUS.

WARNING – EXPLOSION HAZARD – DO NOT REPLACE BATTERIES UNLESS THE AREA IS KNOWN TO BE FREE OF IGNITABLE CONCENTRATIONS.

TEMPERATURE CODE OF T4 FOR ALL MODELS.

PROVIDES NONINCENDIVE FIELD WIRING OUTPUTS/INPUTS WHEN WIRED ACCORDING TO DRAWINGS 50-08-0102 (C5-1-X, C5-2-X) and 50-08-0093 (MV-5-X).

For AEX/EX Class I, Zone 2:

THE EQUIPMENT SHALL ONLY BE USED IN AN AREA OF POLLUTION DEGREE 2.

THE EQUIPMENT SHALL BE INSTALLED COMPLETELY WITHIN AN ENCLOSURE THAT PROVIDES A MINIMUM INGRESS PROTECTION OF IP 54 IN ACCORDANCE WITH UL60079-0 AND ONLY ACCESSIBLE BY THE USE OF A TOOL.

THE WIRE SIZE, TORQUE RATING OF 12-24 AWG, 0.37-0.44 ft. lbs. (0.4-0.5 Nm), AND SUITABLE SUPPLY WIRE TEMPERATURE RATING OF 97°C MINIMUM SHALL BE PROVIDED FOR THE INPUT POWER TERMINAL BLOCK.

ALL MARKING INFORMATION EXCEPT FOR SERIAL NUMBER/DATE CODES SHALL BE REPEATED.

PROVIDES NONINCENDIVE FIELD WIRING OUTPUTS/INPUTS WHEN WIRED ACCORDING TO DRAWINGS 50-08-0102 (C5-1-X, C5-2-X) and 50-08-0093 (MV-5-X).

SPECIAL CONDITIONS FOR USE IECEx/ATEX Zone 2:

THE EQUIPMENT SHALL ONLY BE USED IN AN AREA OF NOT MORE THAN POLLUTION DEGREE 2, AS DEFINED IN IEC/EN 60664-1.

THE EQUIPMENT SHALL BE INSTALLED IN AN ENCLOSURE THAT PROVIDES A DEGREE OF PROTECTION NOT LESS THAN IP 54 IN ACCORDANCE WITH IEC/EN 60079-0 AND ONLY ACCESSIBLE BY THE USE OF A TOOL.

THIS PAGE IS INTENTIONALLY LEFT BLANK

Table of Contents

Installation Manual	1
Operation Manual Location	1
Centurion™ C5 Controller Kit and Tools	1
Inspecting Package Contents.....	1
Tools Needed.....	1
Installation	2
Enclosure / Environmental Requirements	2
M-View® Display Dimensions	3
Install the Display	4
Install the Main Module Controller.....	7
Wire Connections	8
Wire Diagram — MV-5-C Display.....	8
Entity Parameters — MV-5-C Display	9
Wire Diagram — MV-7T Display	10
Wire Diagram — MV-10T Display	10
Wire Diagram — MV-12T Display	10
Wire Diagram — Centurion C5 Controller	11
Entity Parameters — Centurion C5 Controller.....	12
Power Supply and Grounding	16
General Wiring Recommendation	16
Terminal Keys, Blocks and Headers	19
Recommended Wiring Practice for Centurion C5 Terminal Blocks	20
Thermocouple / RTD Inputs (Pins 1 – 16b).....	21
Analog Inputs (Pins 18 – 23b).....	22
Digital Inputs (Pins 30 – 61b).....	23
Power (Pins 62 – 63).....	24
Magnetic Pickup, MPU (Pins 62b – 65).....	25
Analog Outputs (Pins 66 – 659b)	25

Relay Outputs (Pins 70 – 81)	26
FET DC+ (Pins 83 – 89)	27
FET DC– (Pins 90 – 93b)	28
RS485 (Pins 94 – 101)	29
RS232 (Pins 96 – 105)	31
CAN (Pins 106 – 111)	32
Modbus Address	33
Ethernet	34
USB 1 Host	36
USB 2 Device	37
Wi-Fi (C5-1)	38
Accessories	39
Replacement Parts and Assemblies	39
Software Configuration Tool	39
Specifications	40
C5 Series Main I/O Module	40
M-View® Monochrome LCD Display	41
M-View® Touch Series Displays	42

Installation Manual

This manual applies to Centurion C5-1 and C5-2 Application Controllers. C5 and C5 Series refers to both application controllers.

Operation Manual Location

After installation, please review the Centurion C5 Operations Manual prior to placing the controller into service. In order to access the Centurion C5 Operation Manual, please visit the product page to download or print a copy located under the literature tab.

www.fwmurphy.com/Centurion_C5

Centurion™ C5 Controller Kit and Tools

The following instructions will guide you through installing the Centurion C5 controller.

Inspecting Package Contents

Before attempting to install the product, ensure all parts are accounted for and inspect each item for damage (which sometimes occurs during shipping).

Centurion C5 Controller kit includes:

- Centurion C5 Controller
- Centurion C5 Installation Manual (this document) p/n 00-02-0963.

Tools Needed

- Use a 1/4 in. drill bit to make the approximately sized 0.250 in. mounting holes.
- Use a 5/16 in. nut driver to secure star nuts.
- Use a cutout tool (i.e. saw, punch press or cutting wheel) to create the mounting hole according to the dimensions.

Installation

Enclosure / Environmental Requirements

The Centurion Main Module and all M-View displays must be mounted in an enclosure meeting the requirements of IP54 or greater according to the intended use and environmental conditions and in accordance with UL standards and accessible only by use of a tool.

NOTE: IP requirement is ONLY for North America and IECEx/ATEX Zones UL 60079, IEC/EN 60079-0

- Operating temperature -40° to 85°C (-40° to 185°F)
- Altitudes up to 2,000m (6,500ft) (air pressure 0.8/1.1 bar)
- Air with normal oxygen content (typical 21% v/v)
- Maximum relative humidity 95% non-condensing for temperatures up to 85°C (185°F)
- Temperature Class T4
- ic: intrinsic safety (for EPL Gc)
- Increased safety (for EPL Gc)

M-View® Display Dimensions

MV-5

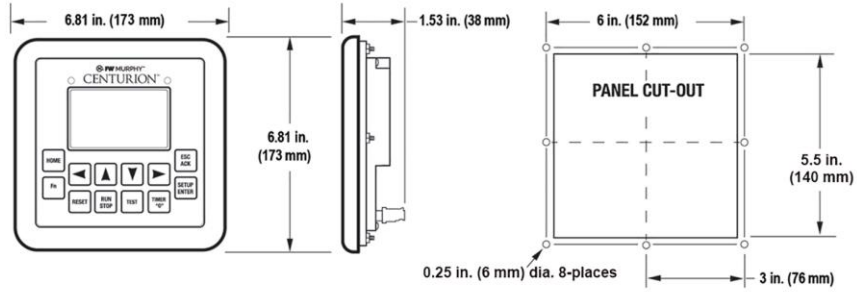

MV-7T

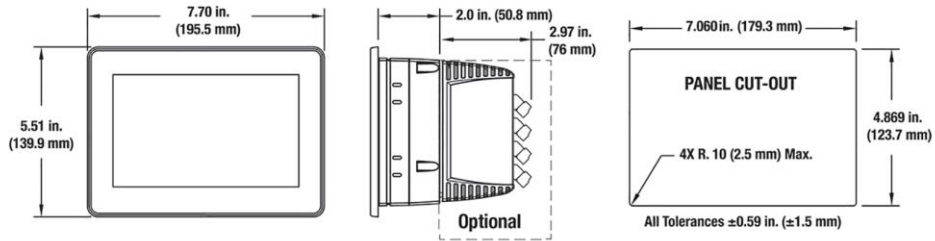

MV-10T

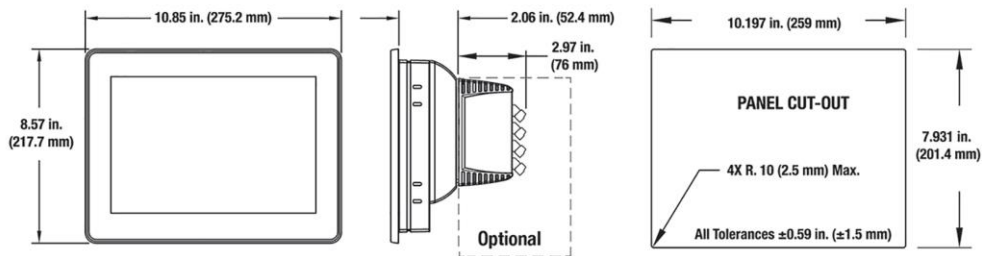

MV-12T

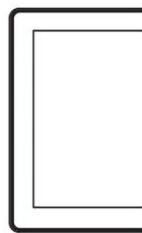
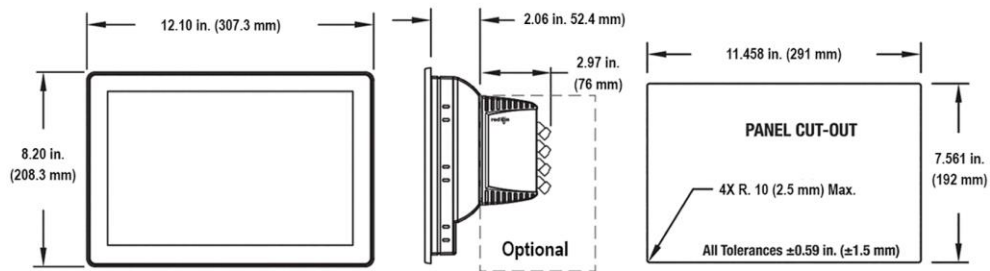

MV-12T



MV-10T



MV-5



MV-7T

Install the Display

Prepare the Panel – All M-View Models

1. Determine the location of the display on the customer-supplied flat or enclosed panel. Plan the display mounting for easy wiring and access.
2. Measure the specified measurements shown in the diagram of the screen side. Doing so will ensure there is adequate real estate to provide clearance for the front edges of the housing to mount flush against the outside surface of your panel. The cut-out measurement will be smaller.
3. Use the diagram to measure and mark the specified dimensions shown in the panel cut-out diagram. This is your cut-out measurement.
4. Cut the hole in the panel following your marks matching the diagram as a guideline.

NOTE: Check for clearance fit of controller in the cutout before proceeding with drilling mounting holes.

5. If applicable, drill holes as indicated for the mounting screws.

MV-5-C Display

The Centurion display can be mounted in the same hole cutouts as the Centurion C4 display. Eight studs and star nuts secure the display bezel to the mounting surface.

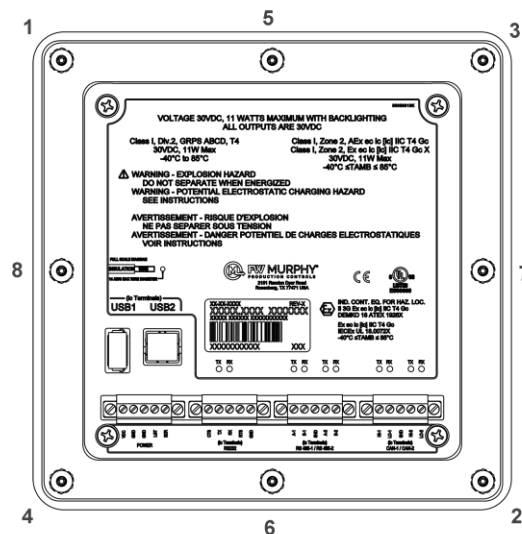

Backside of MV-5-C showing gasket, studs and tightening sequence

1. Insert the display backside first, from the front side of the panel.
2. Ensure that there is adequate clearance for the edges of the display housing and the back of the case is flush against the outside surface of your panel.
3. Install eight-star nuts to the studs from the backside of the panel.
4. Tighten the 5/16" star nuts in sequence to 9 in. lbs. (1 Nm). Do not overtighten.

MV-7T, MV-10T and MV12T Displays

Through-Panel Mount

Once the cutout is prepared in the panel, the M-View Touch can be mounted in the cutout and secured with mounting clips.

1. An O-ring is provided to enable sealing. Inspect the O-ring on the display and ensure it is free from any nicks and properly secured in position.

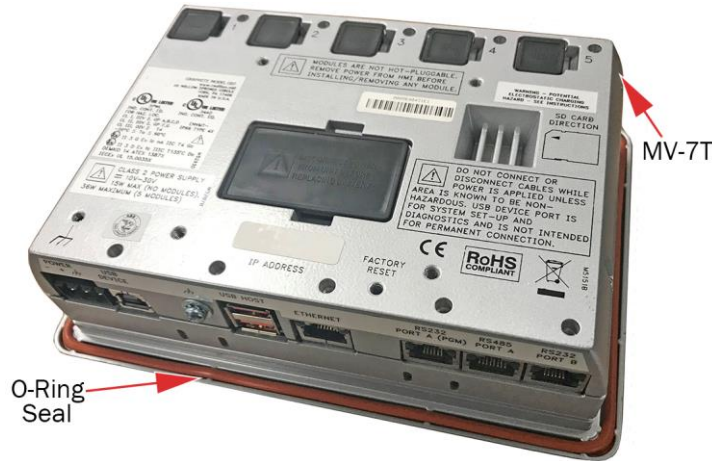

2. Insert the M-View Touch display back side first, from the front side of the panel.
3. Ensure that there is adequate clearance for the edges of the display housing and the back of the case is flush against the outside surface of your panel.
4. Install the mounting clips with screws from the back side of the panel to the display housing and panel.
5. Tighten the mounting clips to 60 in. lbs. (10.5 Nm) evenly for uniform gasket compression. Do not overtighten.

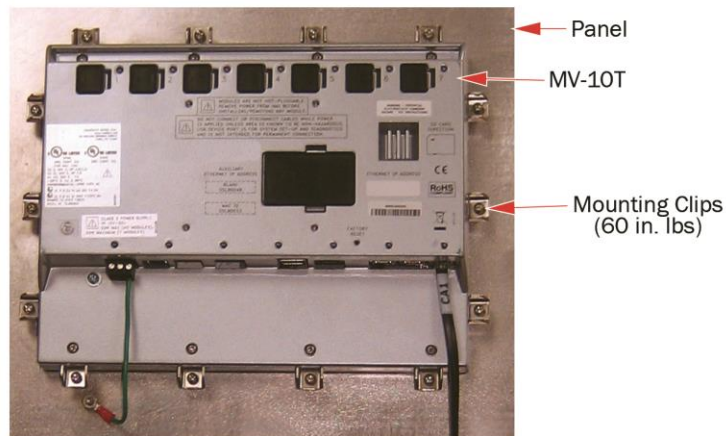
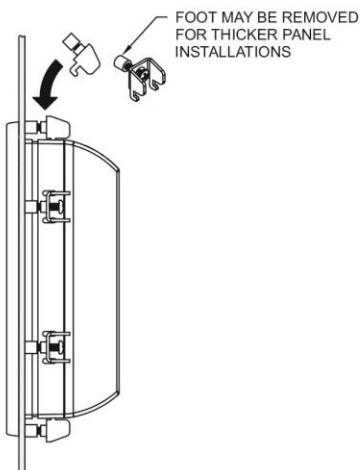

6. Ensure there is a good seal between the controller and the mounting panel.

Stand Mount

Four mount-tapped screw holes (M4 x 0.7, 5 mm deep) are located on the rear of the panels for stand or wall mounting.



MV-7T



MV-12T with stand mount

Tapped Screw Hole Locations

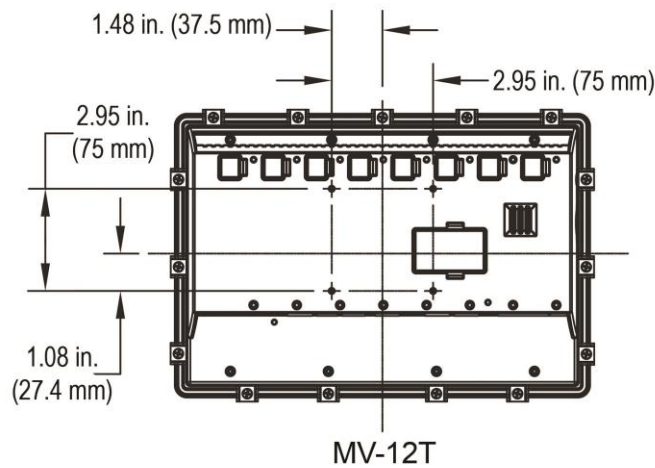
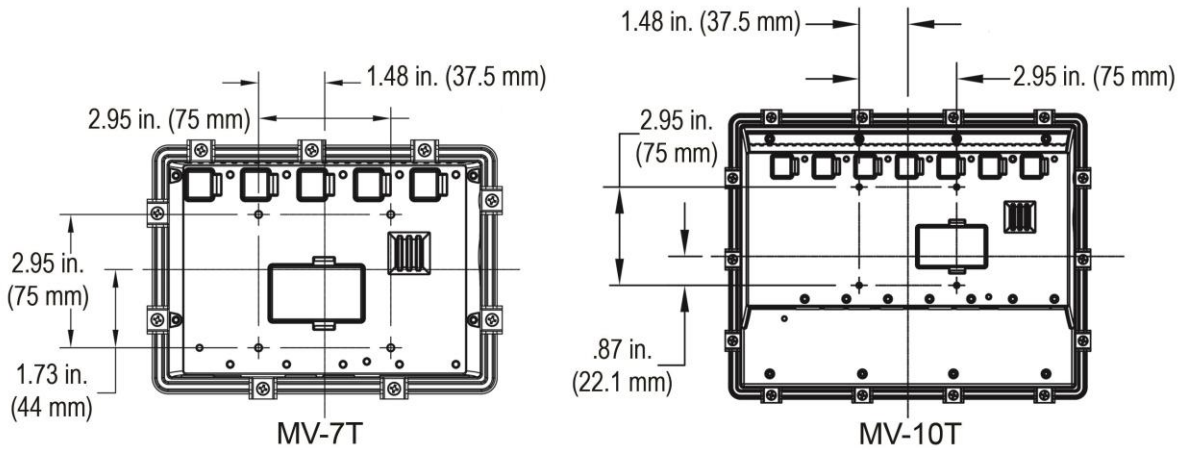

Install the Main Module Controller

The Centurion C5 controller can be mounted vertically or horizontally on a standard DIN rail.

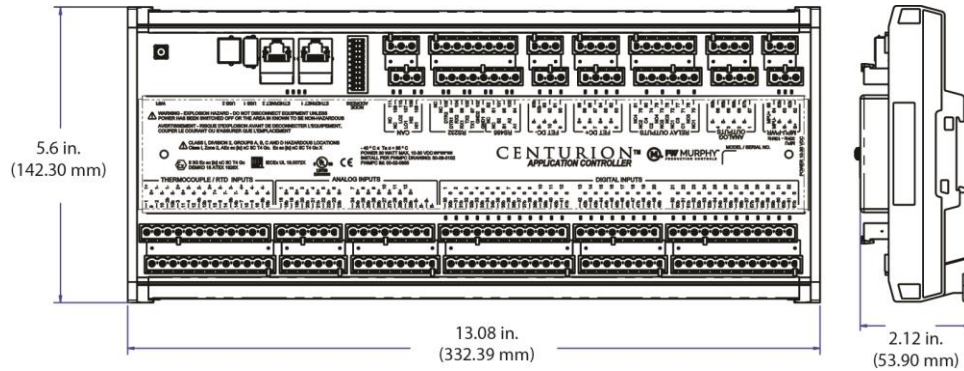

Four clamp-type feet along the bottom of the controller attach to the DIN rail; however, rail stops are recommended to prevent sliding.

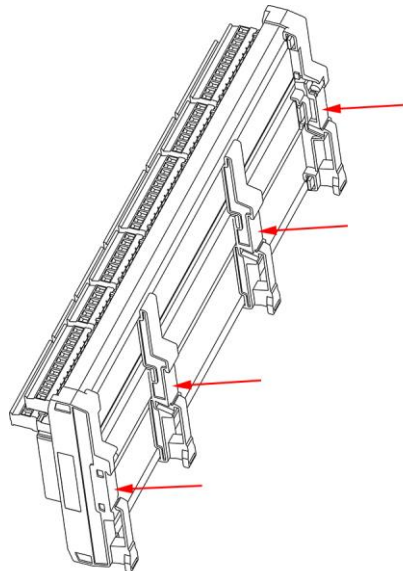

Wire Connections

Wire Diagram — MV-5-C Display

NOTES:

1. FIELD WIRING CONNECTIONS TO BE INSTALLED IN ACCORDANCE WITH NEC FOR CLASS 1, DIV. 2, GROUPS A, B, C, & D LOCATIONS.
2. USE EIA RS-485 SHIELDED TRUSTED PAIR, 120 OHMS CHARACTERISTIC IMPEDANCE CABLE FOR RS-485 AND CANBUS INTERFACE.
3. 120 OHM TERMINATING RESISTOR MAY BE REQUIRED FOR RS-485 AND CANBUS INTERFACE.
4. RS-232 PORT USED FOR DATA COMMUNICATIONS, 5-WIRE CONNECTION PROVIDED, 3-WIRE CONNECTION MOST COMMONLY USED.

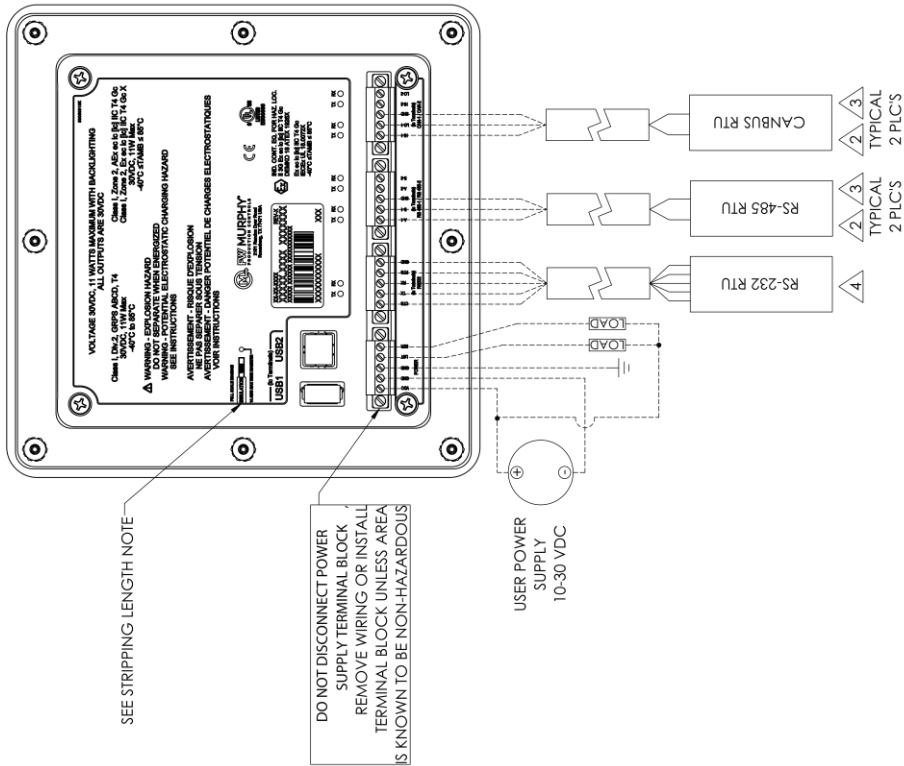
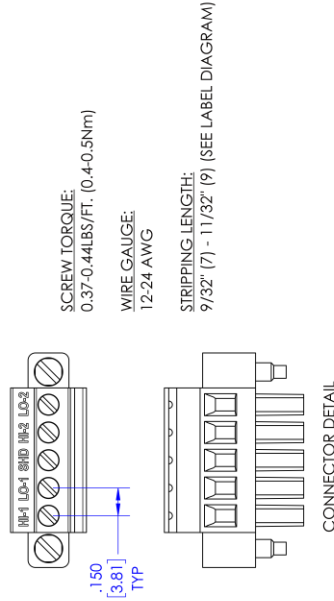

DO NOT SCALE DRAWING DIMENSIONING AND TOLERANCING PER ASME Y14.5 - 2009 APPLY.	INCH		FW MURPHY [®] PRODUCTION CONTROLS	
			DESCRIPTION WIRING DIAGRAM, MV-5, CENTURION	
50080093	50080093		REVISED	F-
50080093.SLDASM	0.7:5:1 AND NOTED	A3	1 OF 3	

Entity Parameters — MV-5-C Display

RS232 J6										
Designation	Uo[V]	Io[mA]	Po[mW]	Lo[mH]	Co[uF]	Ui[V]	Ii[mA]	Pi[mW]	Li[mH]	Ci[uF]
J6 RS232 Transmit/Recieve Pins 1, 2, 3, 4	±15.0	±60	-	22.2	2.99	±30	±60	-	0	0.001
Pin 5	Ground Reference Non-ic									

RS485 J11										
Designation	Uo[V]	Io[mA]	Po[mW]	Lo[mH]	Co[uF]	Ui[V]	Ii[mA]	Pi[mW]	Li[mH]	Ci[uF]
Pins 1, 2	±5.0	±60	-	22.2	999.9	±12.0	±60	-	0	0.01
Pin 3	Ground Reference Non-ic									
Pins 4, 5	±5.0	±60	-	22.2	999.9	±12.0	±60	-	0	0.01
DC-	Ground Pin									

USB										
Designation	Uo[V]	Io[mA]	Po[mW]	Lo[mH]	Co[uF]	Ui[V]	Ii[mA]	Pi[mW]	Li[mH]	Ci[uF]
J7 Type A Pin 1	5.04	±25	-	128	889.8	±5	±500	-	0	110.2
J7 Pin 4	Ground Non-ic									
Pin Tab1, Tab2	Ground Non-ic									
J8 Type B Pin 1	5.04	±25	-	128	889.8	±5	±500	-	0	110.2
J8 Pin 4	Ground Non-ic									
J8 Pins 5, 6	Shield Ground Reference Non-ic									

CAN Per Channel										
Designation	Uo[V]	Io[mA]	Po[mW]	Lo[mH]	Co[uF]	Ui[V]	Ii[mA]	Pi[mW]	Li[mH]	Ci[pF]
J9 Pins 1, 2, 3, 4	4.5	100	-	8	999.9	±24	100	-	51	267
5	Ground Reference Non-ic									

Ethernet Per Port										
Designation	Uo[V]	Io[mA]	Po[mW]	Lo[mH]	Co[uF]	Ui[V]	Ii[mA]	Pi[mW]	Li[mH]	Ci[uF]
J10	3.3	±61.5	-	21.2	999.9	3.3	±60	-	0	0.04

Wire Diagram — MV-7T Display

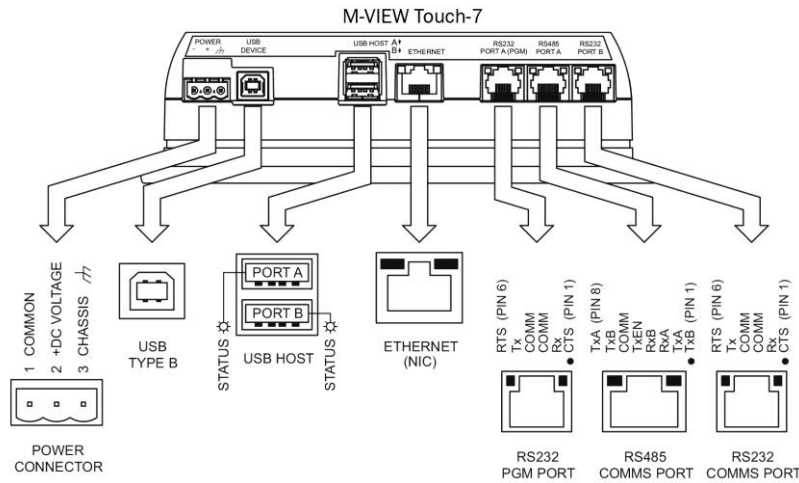

Wire Diagram — MV-10T Display

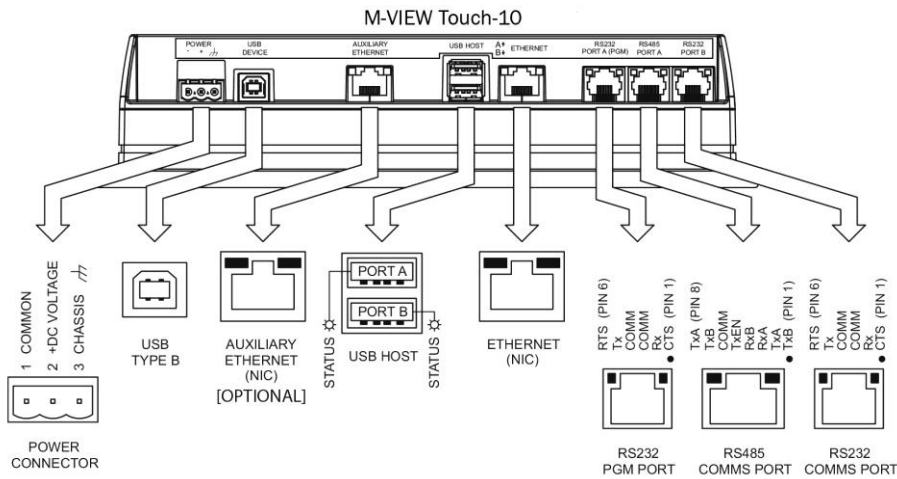

Wire Diagram — MV-12T Display

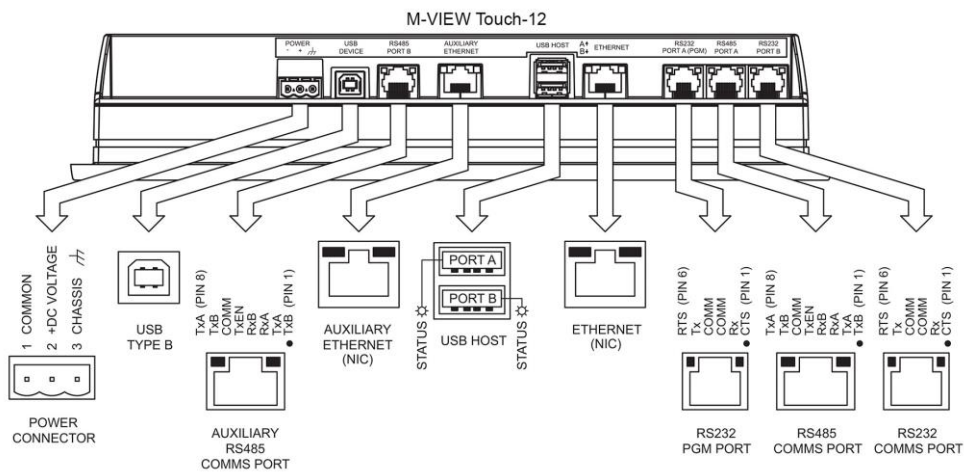

Wire Diagram — Centurion C5 Controller

When applicable, shielded cables may be used on any I/O connection shown. If shielded cable is utilized, only one end of the shielded cable should be grounded.

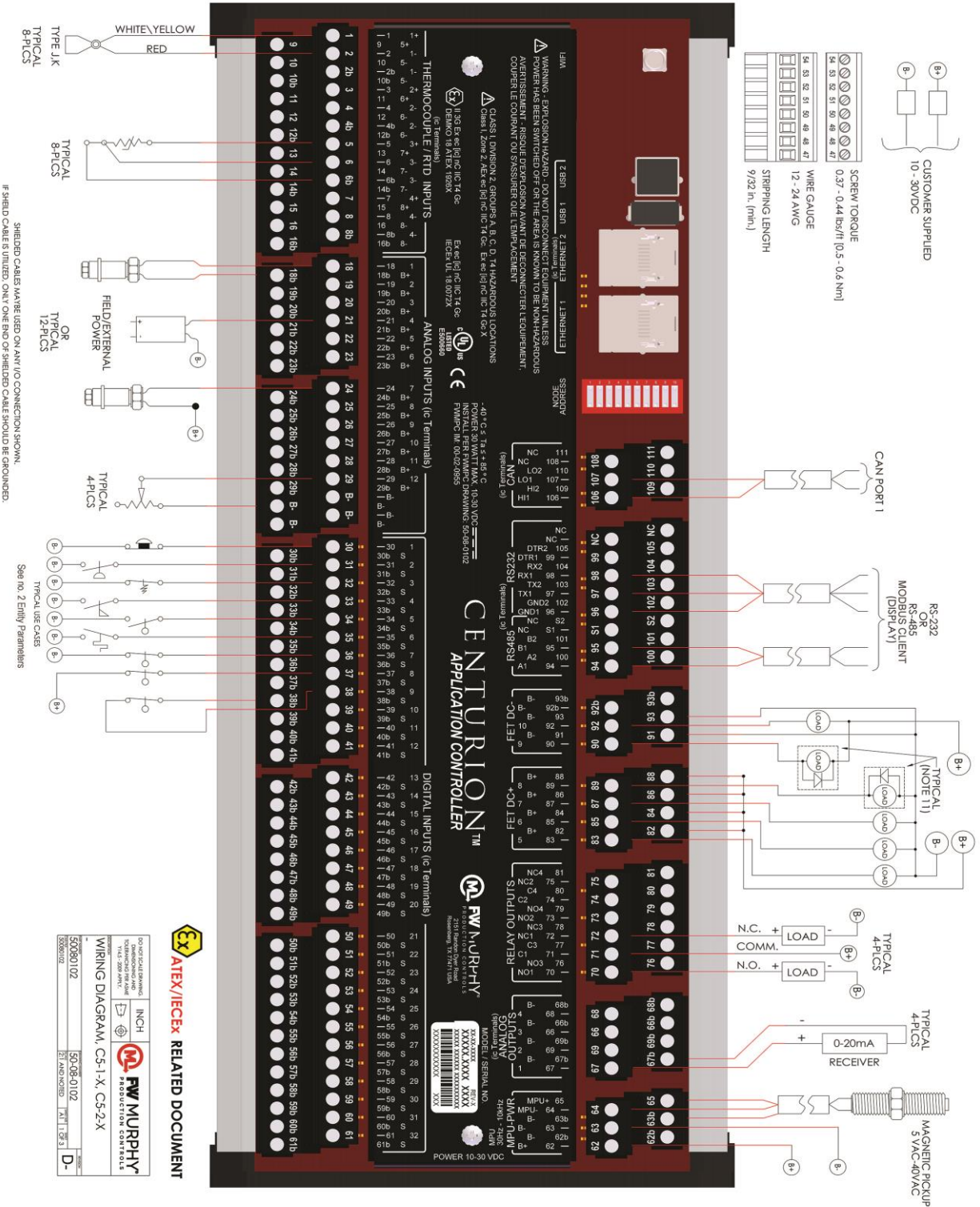

Entity Parameters — Centurion C5 Controller

Inputs/Outputs are only for connections for devices located in Class I, Division 2, Groups A, B, C, D or Class I, Zone 2, Group IIC Hazardous location or ordinary Nonhazardous location or IECEx/ATEX Zone 2, Group IIC with Non-incendive. Simple Apparatus, Intrinsically Safe or approved device with entity concept parameters (U_o , I_o , P_o , C_o , L_o , U_i , I_i , P_i , C_i , L_i) appropriate for connection to associated apparatus with entity concept parameters as listed in the tables.

NOTES:

- The output current of this associated apparatus is limited by a resistor such that the output voltage-current plot is a straight line drawn between open-circuit voltage and short-circuit current. The entity concept allows interconnection of intrinsically safe apparatus with associated apparatus not specifically examined in combination as a system when the approved values of V_{oc} (or U_o) and I_{sc} (or I_o) for the associated apparatus are less than or equal to V_{max} (U_i) and I_{max} (I_i) for the intrinsically safe apparatus. Capacitance and inductance of the field wiring from the intrinsically safe equipment to the associated apparatus shall be calculated and must be included in the system calculations. Cable capacitance, C_{cable} , plus intrinsically safe equipment capacitance, C_i must be less than the marked capacitance, C_a (or C_o), shown on any associated apparatus used. The same applies for inductance (L_{cable} , L_i and L_a or L_o , respectively). Where the cable capacitance and inductance per foot are not known, the following values shall be used: $C_{cable} = 60 \text{ pF/ft.}$, $L_{cable} = 0.2 \text{ } \mu\text{H/ft.}$

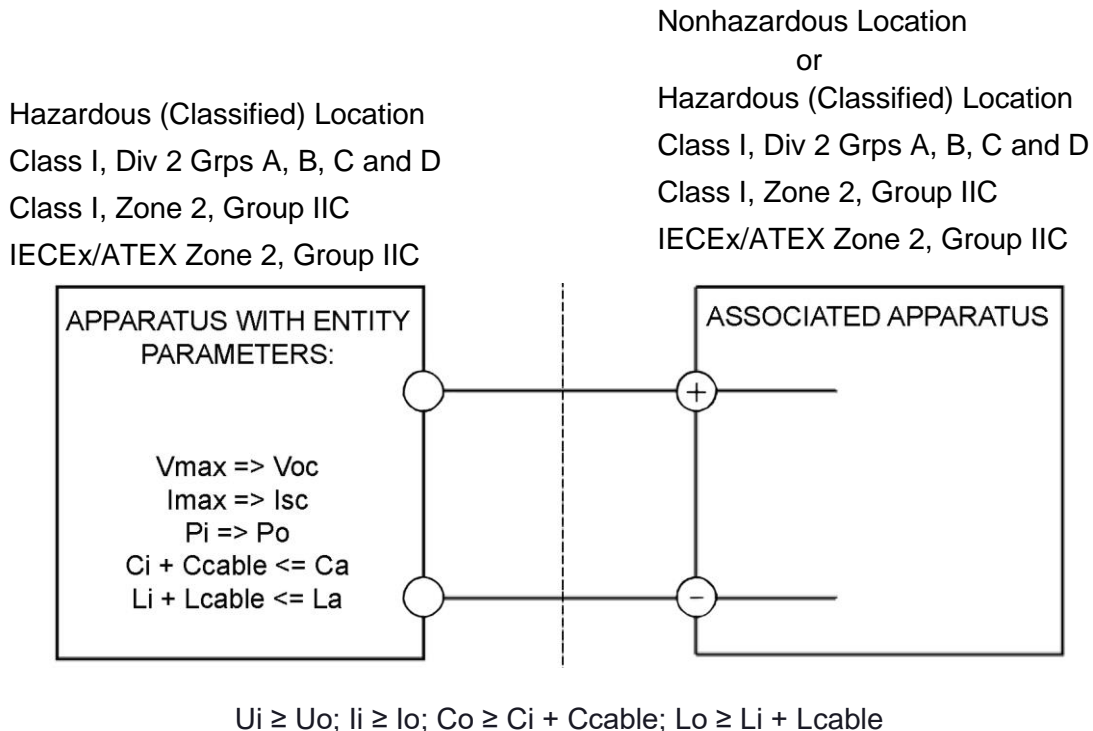

- This associated apparatus may also be connected to non-incendive or simple apparatus as defined in Article 504.2 and installed and temperature classified in accordance with Article 504.10 (B) of the National Electrical Code (ANSI/NFPA 70) or other local codes, as applicable. Examples of simple apparatus are general-purpose contact/switch, thermocouple and RTD.

3. For intrinsically safe devices selected associated apparatus must be third-party listed as providing intrinsically safe circuits for the application or have V_{oc} or V_t not exceeding V_{max} (or U_o not exceeding U_i), I_{sc} or I_t not exceeding I_{max} (or I_o not exceeding I_i), and the P_o of the associated apparatus must be less than or equal to the P_{max} or P_i of the intrinsically safe equipment. Examples of “simple apparatus” are general-purpose contact/switch, thermocouple and RTD.
4. For intrinsically safe devices selected associated apparatus must be third party listed as providing intrinsically safe circuits for application and have V_{oc} or V_t not exceeding V_{max} (or U_o not exceeding U_i), I_{sc} or I_t not exceeding I_{max} (or I_o not exceeding I_i), and the P_o of the associated apparatus must be less than or equal to the P_{max} or P_i of the intrinsically safe equipment.
5. Where multiple circuits extend from the same piece of associated apparatus, they must be installed in separate cables or in one cable having suitable insulation. Refer to Article 504.30(B) of the National Electrical Code (ANSI/NFPA 70) and Instrument Society of America Recommended Practice ISA RP12.6 for installing intrinsically safe equipment.
6. Intrinsically safe circuits must be wired and separated in accordance with Article 504.20 of the National Electrical Code (ANSI/NFPA 70) or other local codes, as applicable.
7. This associated apparatus has not been evaluated for use in combination with another associated apparatus.
8. Control equipment must not use or generate more than 250 V rms or dc with respect to earth.
9. For installations in which both the C_i and L_i of the intrinsically safe apparatus exceeds 1% of the C_o and L_o parameters of the associated apparatus (excluding the cable), then 50% of C_o and L_o parameters are applicable and shall not be exceeded.
10. This equipment is suitable for use in non-hazardous locations and hazardous locations Zone 2, Group IIC T4 or Class I, Division 2, Groups A, B, C, D Temperature Code T4 Installations.
11. If an inductive load does not have an internal flyback diode, it is recommended you install a 1A 600V diode in parallel with the load (1N4005 – EC P/N 36-16-1002).
12. Use two conductor cable with foil shield and drain wire for MPU input.
13. This equipment must be mounted in an enclosure meeting the requirements of IP54 or greater according to the intended use and environmental conditions.
14. Installation is to be done only by a qualified technician of the responsible body.
15. Device shall be wired in accordance with NEC, CEC or other local code, as applicable.



WARNING:

EXPLOSION HAZARD - DO NOT DISCONNECT THE EQUIPMENT OR ACTUATE SWITCHES WHEN THE EQUIPMENT IS ENERGIZED AND AN EXPLOSIVE ATMOSPHERE IS PRESENT.

EXPLOSION HAZARD - DO NOT DISCONNECT EQUIPMENT UNLESS POWER HAS BEEN SWITCHED OFF OR THE AREA IS KNOWN TO BE NON-HAZARDOUS.

Entity Parameters — Centurion C5 Controller (continued)

Thermocouple/RTD Inputs (Per Pin)										
Designation	Uo[V]	Io[mA]	Po[mW]	Lo[H]	Co[μF]	Ui[V]	Ii[mA]	Pi[mW]	Li[mH]	Ci[μF]
J1 Pins 2, 4, 6, 8, 10, 12, 14, 16	4.4	1.0	4.4	80	999.9	30.0	17.0	-	0	0.1
J1 Pins 1, 2b, 3, 4b, 5, 6b, 7, 8b, 9, 10b, 11, 12b, 13, 14b, 15, 16b	4.4	1.0	4.4	80	995.1	30.0	17.0	-	0.022	4.9

Analog Inputs (Per Pin)										
Designation	Uo[V]	Io[mA]	Po[mW]	Lo[mH]	Co[mF]	Ui[V]	Ii[mA]	Pi[mW]	Li[mH]	Ci[μF]
J2-J3 AI1-AI8 Pins 18-25	-	-	-	-	-	10.3	51.6	-	0	0.1
J3 AI9-AI12 Pins 26-29	4.4	1.0	-	80	995.1	10.3	51.6	-	0.022	4.9
J2-J3 AB+ Pins 18b-29b	-	-	-	-	-	-	-	-	-	-
B-	Ground Pin									

Digital Inputs (Per Pin)										
Designation	Uo[V]	Io[mA]	Po[mW]	Lo[mH]	Co[μF]	Ui[V]	Ii[mA]	Pi[mW]	Li[mH]	Ci[μF]
J4-J6 DI1-DI32 Pins 30-31	30	5.2	-	2.95	0.120	30	17	-	0	0.1
J4-J6 B+1 to B+32 Pins 30b-61b	30	12.66	-	500	0.120	-	-	-	0	0.1

Analog Outputs(Per Pin)										
Designation	Uo[mV]	Io[mA]	Po[mW]	Lo[mH]	Co[μF]	Ui[V]	Ii[mA]	Pi[mW]	Li[mH]	Ci[μF]
J8 Pins 66-69	30	38.5	-	54	0.120	-	-	-	0	0.1
J8 Pins 66b-69b	Analog Output Ground									

Entity Parameters — Centurion C5 Controller (continued)

RS485/RS232										
Designation	Uo[V]	Io[mA]	Po[mW]	Lo[mH]	Co[uF]	Ui[V]	Ii[mA]	Pi[mW]	Li[mH]	Ci[uF]
J12 RS485 Pins 94, 95 100, 101	±5.0	±60	-	22.2	999.9	±12.0	±60	-	0	0.01
J12 Pins S1, S2	Shield Connection Ground									
J12 RS232 Pins 96,102	Shield Reference Ground									
J12 RS232 Transmit/Receive Pins 97-99 103-105	±15.0	±60	-	22.2	2.99	±30	±60	-	0	0.001

CAN Per Channel										
Designation	Uo[V]	Io[mA]	Po[mW]	Lo[H]	Co[uF]	Ui[V]	Ii[mA]	Pi[mW]	Li[mH]	Ci[pF]
J13 Pins 106-111	±4.5	±5	-	3.2	999.9	±24	100	-	0	267

USB										
Designation	Uo[V]	Io[mA]	Po[mW]	Lo[mH]	Co[uF]	Ui[V]	Ii[mA]	Pi[mW]	Li[mH]	Ci[uF]
J16 Type A	±5.19	±25	-	128	889.8	±5	±500	-	0	110.2
J17 Type B	±3.3	±25	-	128	999.8	±5	±500	-	0	0.200

Ethernet Per Port										
Designation	Uo[mV]	Io[mA]	Po[mW]	Lo[mH]	Co[uF]	Ui[V]	Ii[mA]	Pi[mW]	Li[mH]	Ci[uF]
J14-J15	3.3	±61.5	-	21.2	999.9	3.3	±60	-	0	0.1

MPU – Entity Parameters											
Designation	Type of Protection	Uo[V]	Io[mA]	Po[mW]	Lo[mH]	Co[uF]	Ui[V]	Ii[mA]	Pi[W]	Li[mH]	Ci[uF]
63b, 64 Pins	nA	-	-	-	0	0	-	-	-	-	-
65 Pin	nA	-	-	-	0	0	40	0.001	.012	-	0.220

Power Supply and Grounding

Please refer to the Wire Diagram — Centurion C5 Controller for grounding requirements.

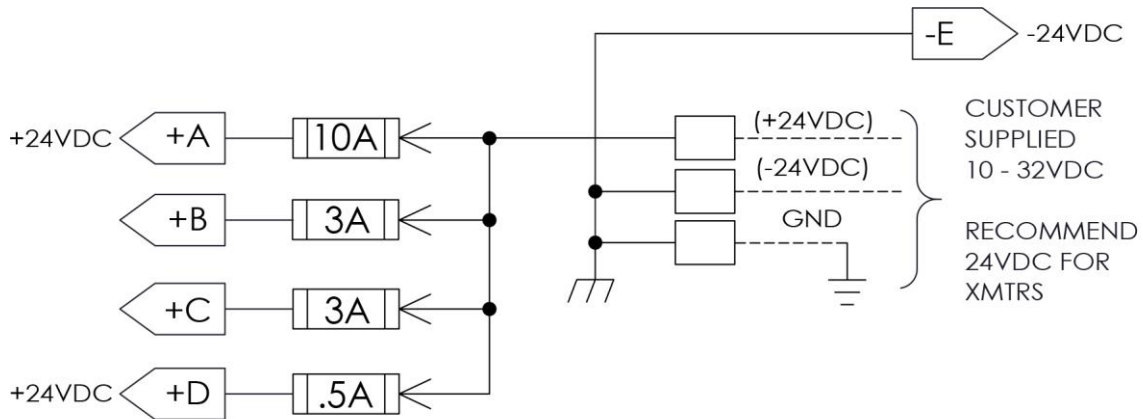

NOTE: Follow the instructions for protective earthing.

General Wiring Recommendation

It is essential that the following practices be adhered to.

Terminals for Safe Circuits

Terminals for intrinsically safe circuits shall be separated from terminals for non-intrinsically safe circuits by one or more of the methods given. These methods of separation shall also be applied where intrinsic safety can be impaired by external wiring which, if disconnected from the terminal, can come in contact with conductors or components.

When separation is accomplished by distance then the clearance between bare conducting parts and terminals shall be at least 50 mm.

Care should be exercised in the layout of terminals and in the wiring method used so that contact between circuits is unlikely if a wire becomes dislodged.

Terminal Separation

When separation is accomplished by locating terminals for intrinsically safe and non-intrinsically safe circuits in separate enclosures or by use of either an insulating partition or an earthed metal partition between terminals with common cover, the following applies:

- Partitions used to separate terminals shall be within 1.5 mm of the enclosure walls or alternatively shall provide a minimum distance of 50 mm between bare conduction parts of terminals when measured in any direction around the partition.
- Metal partitions shall be earthed and shall have sufficient strength and rigidity to ensure that they are not likely to be damaged during field wiring. Such partitions shall be at least 0.45 mm thick or shall conform to 10.6.3 of Standard 60079-11 if of lesser thickness. In addition, metal partitions shall have sufficient current-carrying capacity to prevent burn-through or loss of earth connection under fault conditions.
- Non-metallic insulating partitions shall have an appropriate CTI, sufficient thickness and shall be so supported that they cannot readily be deformed in a manner that would defeat their purpose. Such partitions shall be at least 0.9 mm thick or shall conform to 10.6.3 of Standard 60079-11 if of lesser thickness.

The clearances and creepage distances between the bare conducting parts of terminals of separate intrinsically safe circuits and to earthed or potential-free conducting parts shall be equal to 0.8 mm (for 32V “ic” clearance).

Where separate intrinsically safe circuits are being considered, the clearance between bare conducting parts of external connection facilities shall meet the following:

- At least 6 mm between the separate intrinsically safe circuits.
- At least 3 mm from earthed parts, if connection has not been considered in the safety analysis.

Terminal Separation Schematic

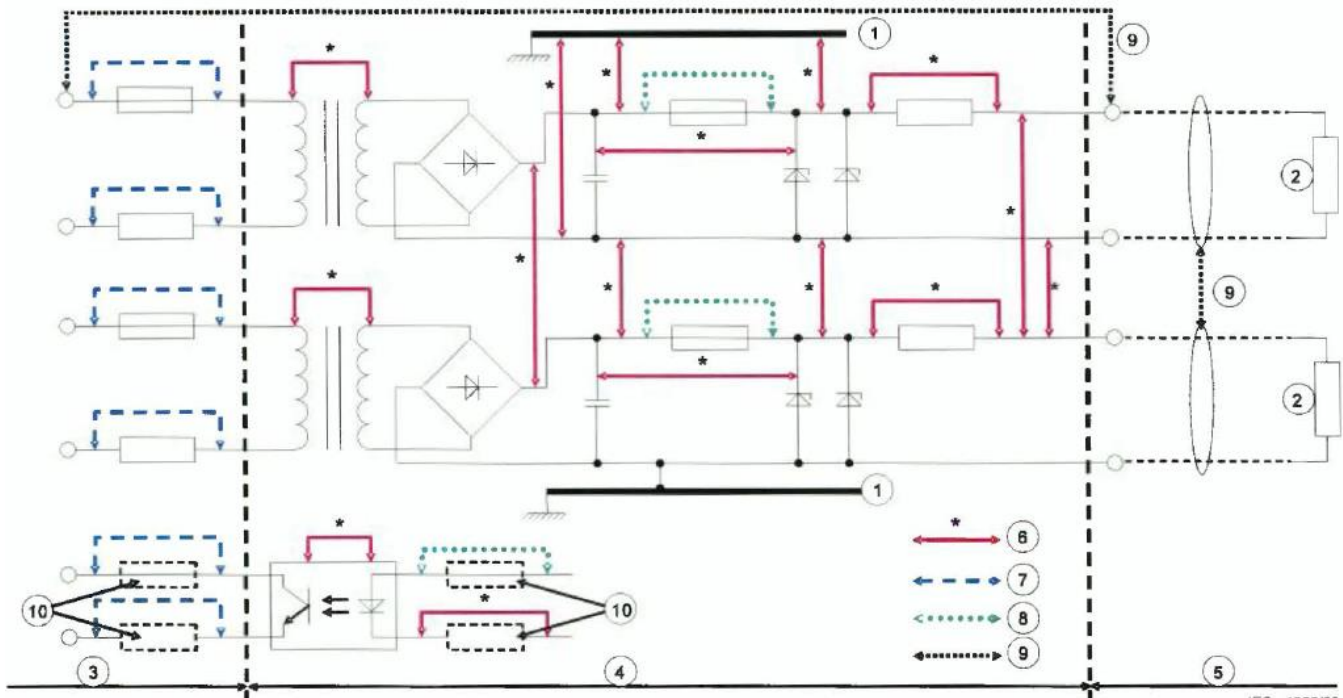

Callout	Description
1	Chassis
2	Load
3	Non-intrinsically safe circuits defined by U_m
4	Part of intrinsically safe circuit not itself intrinsically safe
5	Intrinsically safe circuit
6	Dimensions of separation in the apparatus
7	Dimensions to which general industrial standards are applicable
8	Dimensions to separation in the apparatus
9	Dimensions to 6.2.1 for output terminals between separate intrinsically safe circuits and between intrinsically safe to non-intrinsically safe circuits
10	Protective components as applicable in accordance with 8.9

Terminal Keys, Blocks and Headers

Some keys on the terminal block are visible by the raised area and color, while others may only have the raised area. This is an example of the keys on four terminal blocks.

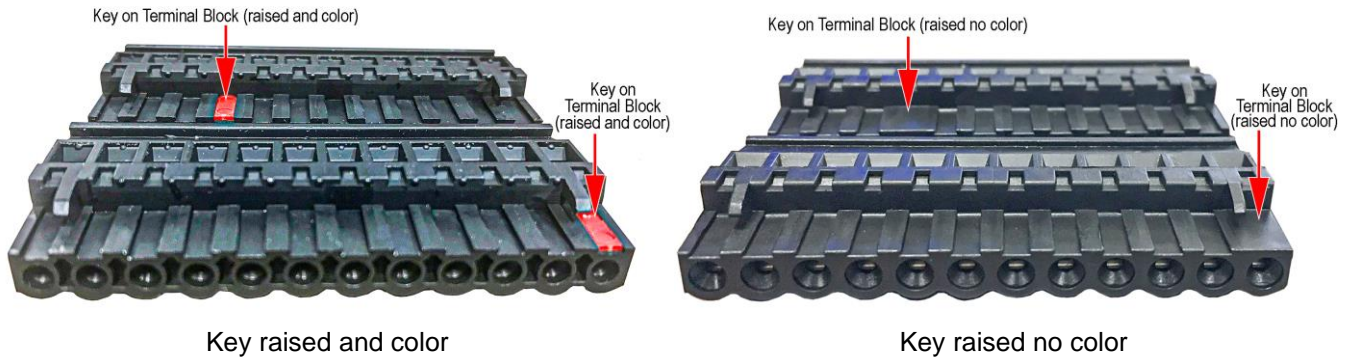

IMPORTANT: Never align the Terminal keys, doing so will block proper mating of the terminal block to header.

Terminal blocks and headers are equipped with blocking-type keys. When connecting, Do Not align the key on the terminal block with the key on the header. Doing so will block proper mating of the terminals. This example shows the correct and incorrect connection.

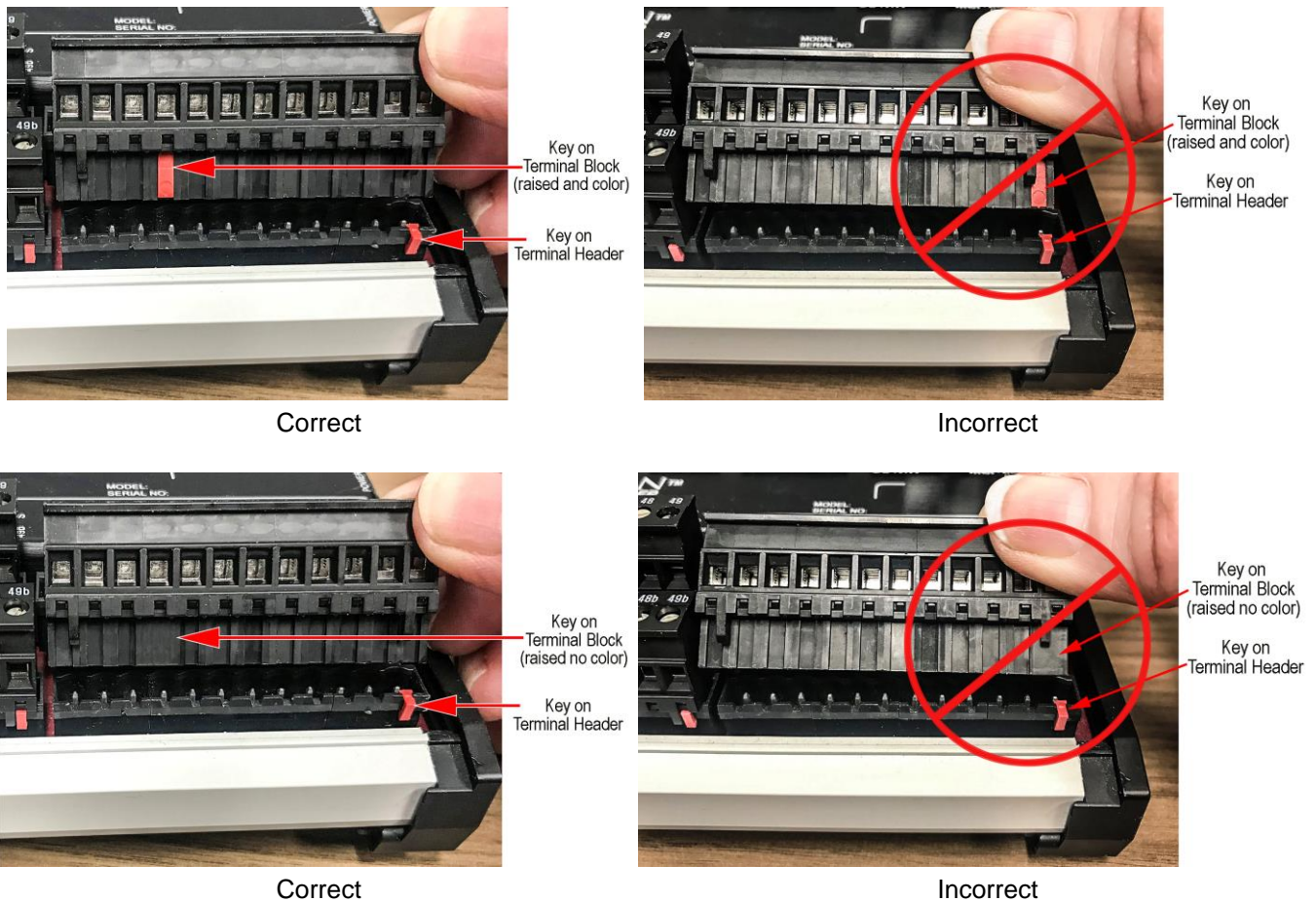

Recommended Wiring Practice for Centurion C5 Terminal Blocks

NOTE: The terminal block must be removed from the headers on the control and any expansion modules before attempting any maintenance on the wired system or any job requiring a hot work permit. Please ensure that the work area is non-hazardous before removing or installing any terminal block. The system should also be powered off in jobs involving hot work permits, and any such instructions established by safety standards at the job site must be complied with at all times.

Use a wire size between 12 AWG (max.) and 24 AWG (min.) to connect to the terminal strip connector. Strip the insulation back 9/32 inches and twist the exposed wires tightly together. Insert the exposed wire completely into the terminal strip and securely tighten the clamping screw. Wires must be in good condition or replaced with new wires. When running wires, take care not to damage the insulation and take precautions against later damage from vibration, abrasion or liquids in conduits. An explosion-proof conduit is not required; however, wires should be protected from damage by running them in a protective conduit or in sheaths where appropriate.

Pitch	0.200 in. [5.08mm]
Screw Torque	0.37 - 0.44 ft. lbs [0.5 – 0.6 Nm]
Stripping Length	9/32 in. (min.) [7 mm]
Wire Gauge	24 – 12 AWG/kcmil
Nominal voltage UN	300 V
Nominal current IN	10 A
Conductor cross section solid or stranded	0.2 – 2.5 mm ²
Conductor cross section stranded, with ferrule with or without plastic sleeve	0.25 – 2.5 mm ²
2 conductors with same cross section, solid	0.2 – 1 mm ²
2 conductors with same cross section, stranded	0.2 – 1.5 mm ²
2 conductors with same cross section, stranded, ferrules without plastic sleeve	0.25 – 1 mm ²
2 conductors with same cross section, stranded, TWIN ferrules with plastic sleeve	0.5 – 1.5 mm ²

Thermocouple / RTD Inputs (Pins 1 – 16b)

The Centurion is equipped with 8 two-wire thermocouple and /or three-wire RTD inputs.

Thermocouples are wired using cover artwork labeled as + and -, such as 1+ and 1-. Thermocouple terminals can be seen labeled as 1 and 2 for TC 1 channel and 3 and 4 for TC 2 channel and so on. Use ungrounded thermocouples only, grounded thermocouples are not supported.

When RTD is selected for the channel, 3 terminals are required. RTDs are wired using cover artwork labeled with the same + and - but also includes an additional - (minus) for the sense lead.

RTDs terminals can be seen labeled as 1, 2, 2b for the first channel and 3, 4, 4b for the next channel and so on.

NOTE: This wiring differs from the MX4-R2 module wiring of RTDs.

Important: For Entity Parameters or Power Supply and Grounding, refer to Wire Connections.

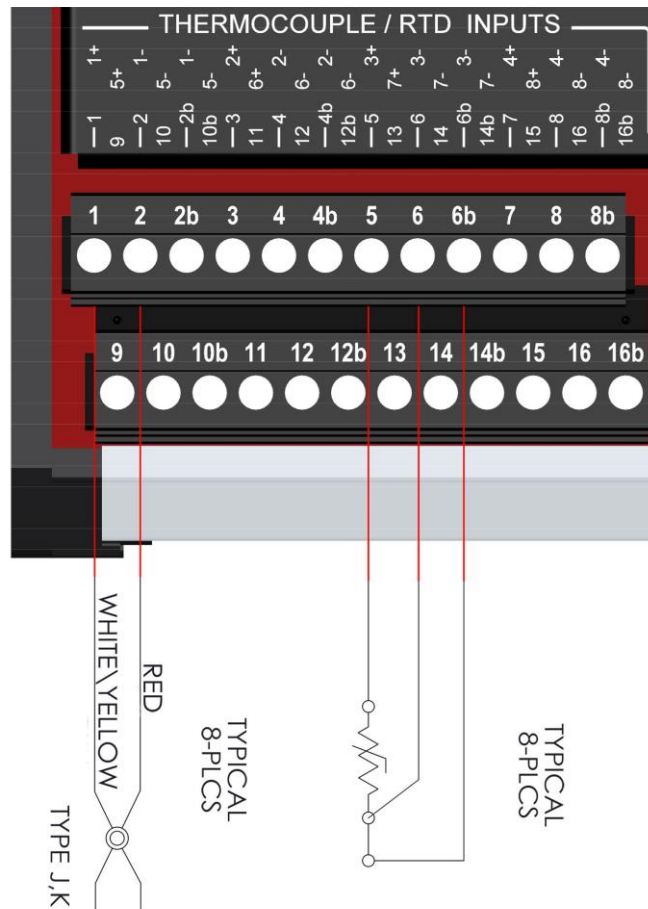

NOTE: These circuits are not required to be in conduit if all the requirements for ic protection are met and Authority Having Jurisdiction (AHJ) allows.

Analog Inputs (Pins 18 – 23b)

The Centurion is equipped with 12 analog inputs marked 18 through 23b. Analog inputs 9 through 12 will supply 1mA for connection to resistive senders. 0 to 5Vdc or 4 to 20 mA.

Important: For Entity Parameters or Power Supply and Grounding, refer to Wire Connections.

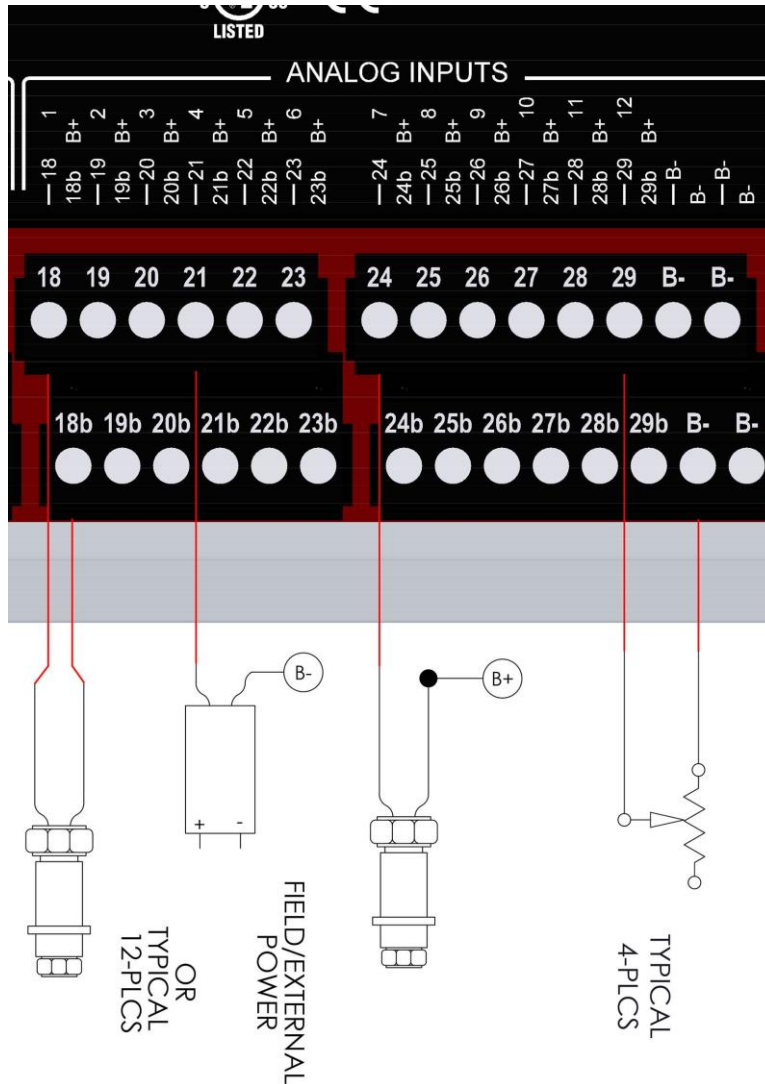

NOTE: These circuits are not required to be in conduit if all the requirements for ic protection are met and Authority Having Jurisdiction (AHJ) allows.

Devices that are self-powered, 4-wire devices, such as flowmeters and VFD drives, do not receive power from the panel and offer a pure current loop.

Digital Inputs (Pins 30 – 61b)

The Centurion is equipped with 32 digital inputs marked 30 through 61 for the input and 30b through 61b for ic protected power to loop through the external switch back to the input. Alternately the external switch may use B+ or B- to activate the digital input. An LED lights when the digital input is active. Inputs 31 and 32 can alternately be used as pulse counters.

Important: For Entity Parameters or Power Supply and Grounding, refer to Wire Connections.

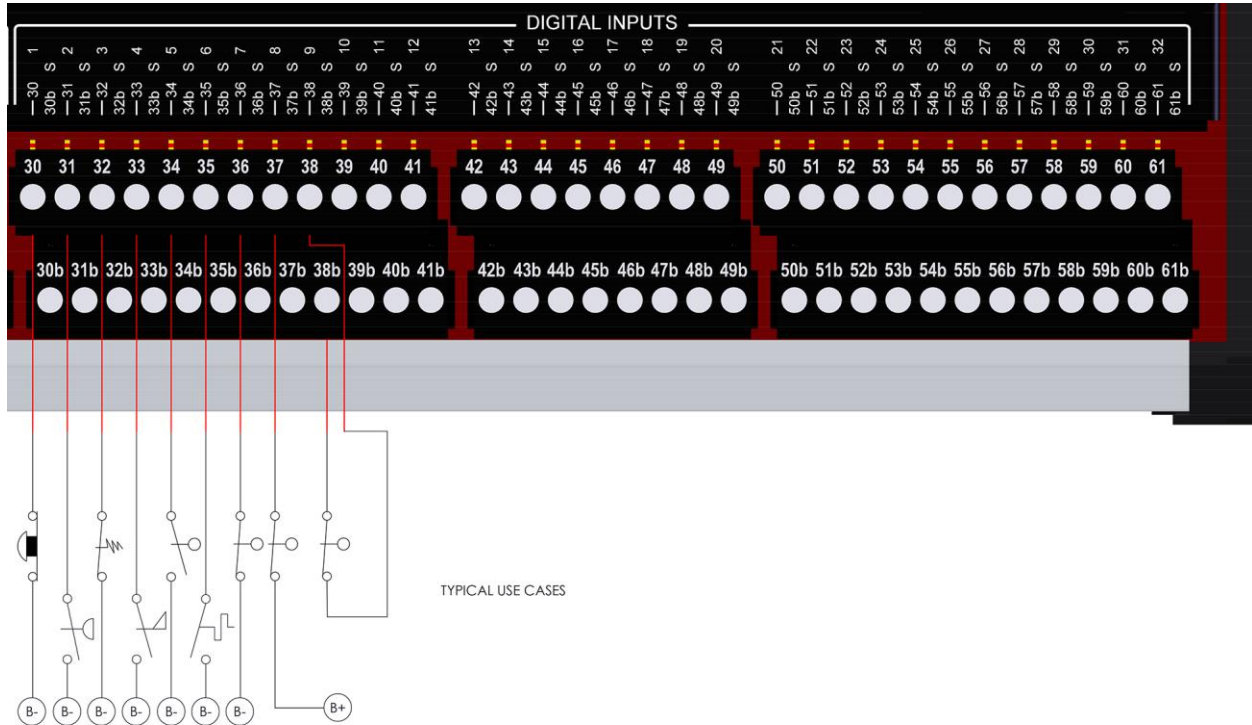

NOTE: This associated apparatus may also be connected to non-incendive or simple apparatus as defined in Article 504.2 and installed and temperature classified in accordance with Article 504.10(B) of the National Electrical Code (ANSI/NFPA 70), or other local codes, as applicable. Examples of “simple apparatus” are general-purpose contact/switch, thermocouples and RTD.

NOTE: These circuits are not required to be in conduit if all the requirements for ic protection are met and Authority Having Jurisdiction (AHJ) allows.

Power (Pins 62 – 63)

The 10-30 VDC power for the Centurion C5 is applied to the power supply terminals marked 62 B+ and 63 B-. An external 10 amp replaceable fuse protects the system from over-currents. The power LED lights when power is applied to the system. Please refer the section Power Supply and Grounding for illustrations.

Important: For Entity Parameters or Power Supply and Grounding, refer to Wire Connections.

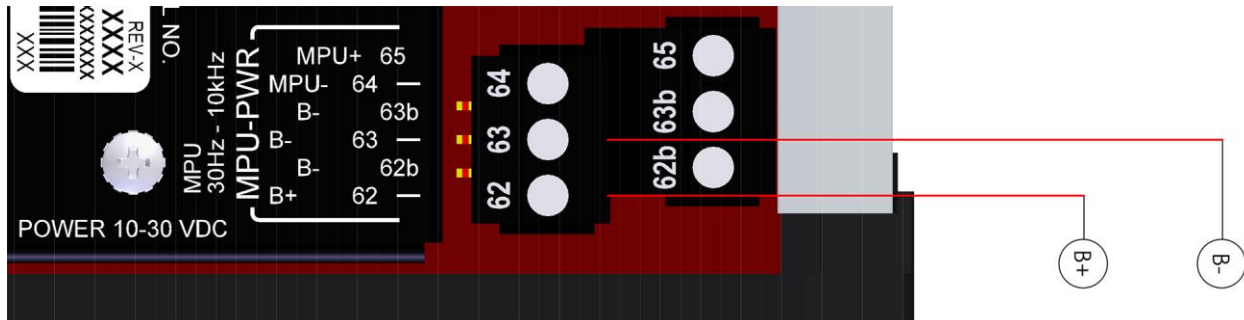

NOTE: Run power directly from battery posts to controller power terminals when battery is the power supply.

Maximum power ratings based on all I/O operating in the ON position with 10V supply. Typical based on 24V supply.

Magnetic Pickup, MPU (Pins 62b – 65)

The MPU for the Centurion is applied to the magnetic pickup terminals marked 64 MPU- and 65 MPU+, MPU 5-40Vrms 30-10 kHz. If used, the foil shield and drain wire of the cable assembly may be terminated at 62b- or 63b-. The MPU sends the pulses to the controller, which calculates the engine speed.

FW Murphy recommends using 00031022 Magnetic Pickup 4 in. Length and 00031023 Magnetic Pickup Cable 50 ft.

Important: For Entity Parameters or Power Supply and Grounding, refer to Wire Connections.

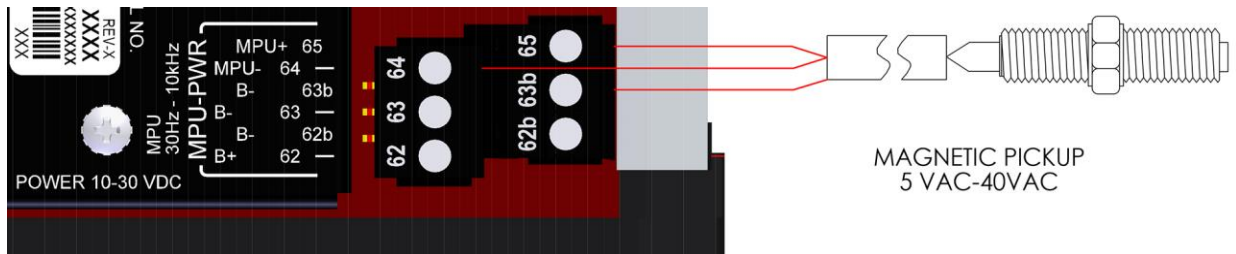

NOTE: The MPU input requires a minimum signal of 2 Vrms when connected.

Analog Outputs (Pins 66 – 659b)

The Centurion is equipped with four 2-wire current transmitters for controlling various processes. The supply voltage and measuring currents are supplied by the Centurion over the same two wires. These transmitters are used to convert various process signals representing flow, speed, position, level, temperature, pressure, etc., to 4-20mA DC for the purpose of transmitting the signal over some distance with little or no loss of signal.

Important: For Entity Parameters or Power Supply and Grounding, refer to Wire Connections.

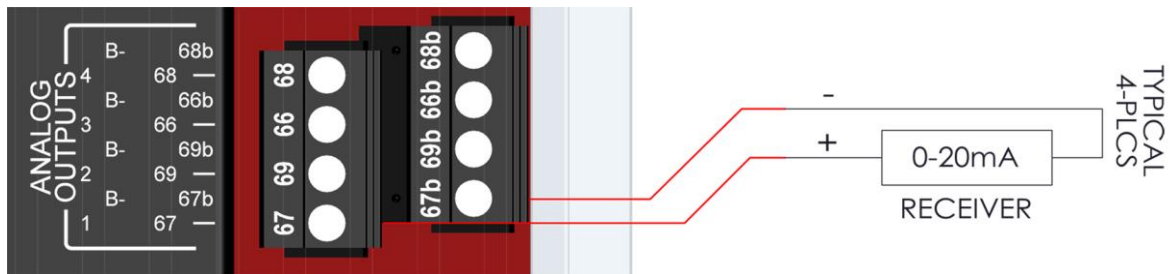

NOTE: The Centurion provides all operating power (~B+) to the transmitter and receiver and any other loop components.

An important aspect of building a current loop system is avoiding ground loops by wiring the return signal to the associate B- terminal.

These circuits are not required to be in conduit if all the requirements for ic protection are met and Authority Having Jurisdiction (AHJ) allows.

Relay Outputs (Pins 70 – 81)

The Centurion is equipped with four SPDT (1 Form C) relays with 5A 30Vdc dry contacts. The four relay contacts are marked 70 NO1 71 C1 72 NC1; 73 NO2 74 C2 75 NC2; 76 NO3 77 C3 78 NC3; and 79 NO4 80 C4 81 NC4. An LED lights when the relay is active.

Important: For Entity Parameters or Power Supply and Grounding, refer to Wire Connections.

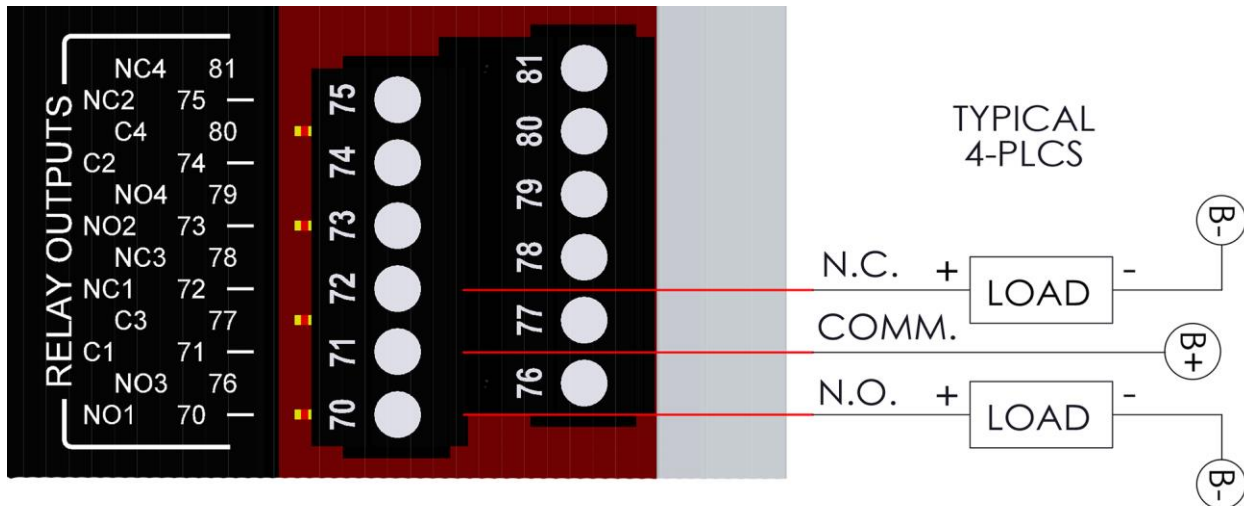

NOTE: If an inductive load does not have an internal flyback diode, it is recommended you install a 1A 600V PIV diode in parallel with the load. (1N4005 – EC P/N 36-16-1002)

To ground ignition use pilot relay with 25 Ω 3 W series resistor to ground.

Interposing relays are recommended to interface with end devices that require high current ratings or alternative voltage supplies.

Consult General Cautions for Solid-State Devices for best practices when connecting to external inductive load devices such as relays or solenoids.

www.fwmurphy.com/other-support-resources/general-cautions-solid-state-devices

FET DC+ (Pins 83 – 89)

The Centurion is equipped with four High Side 100 mΩ max Switches. The four switches are marked 82-83; 84-85; 86-87 and 88-89. An LED lights when the switch is active.

Important: For Entity Parameters or Power Supply and Grounding, refer to Wire Connections.

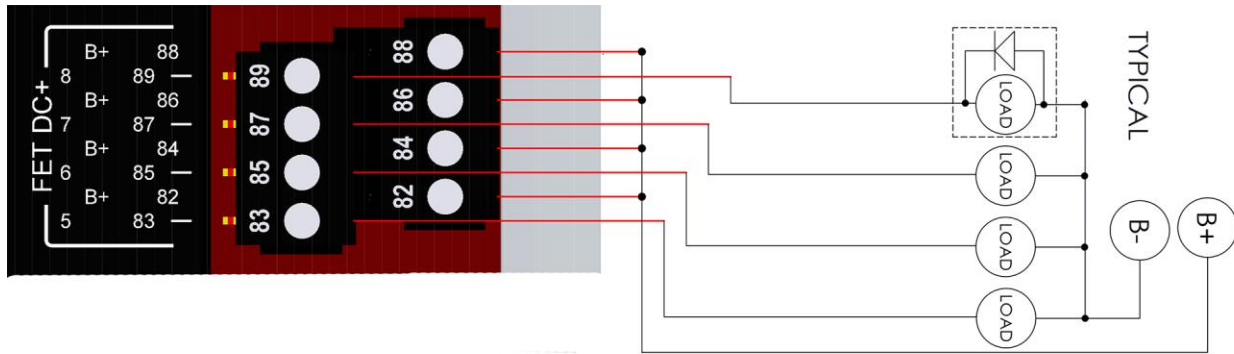

NOTE: If an inductive load does not have an internal flyback diode, it is recommended you install a 1A 600V PIV diode in parallel with the load. (1N4005 – EC P/N 36-16-1002)

To ground ignition, use pilot relay with 25 Ω 3 W series resistor to ground. Interposing relays are recommended to interface with end devices that require high current ratings or alternative voltage supplies.

Consult General Cautions for Solid-State Devices for best practices when connecting to external inductive load devices such as relays or solenoids. www.fwmurphy.com/other-support-resources/general-cautions-solid-state-devices

FET DC- (Pins 90 – 93b)

The Centurion is equipped with two Low Side 250 mΩ max Switches. The two switches are marked 90-91 and 92-93. There are also two terminals, 92b- and 93b-, for shield termination. The LED lights when the switch is active.

Important: For Entity Parameters or Power Supply and Grounding, refer to Wire Connections.

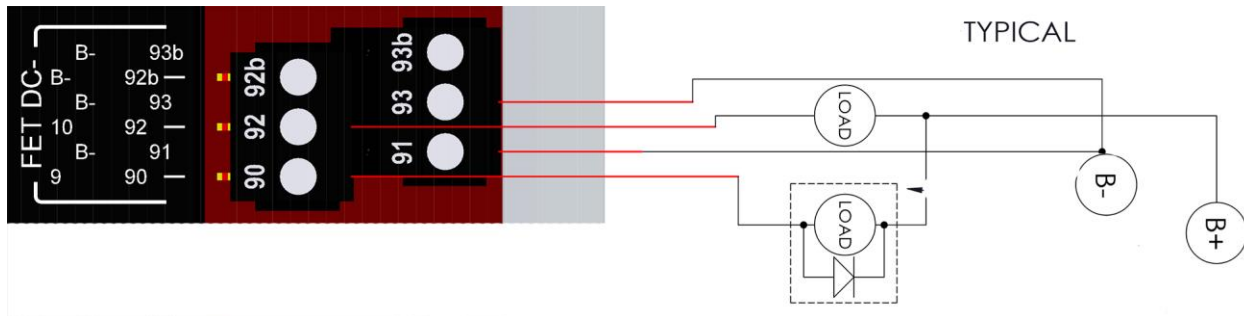

NOTE: If an inductive load does not have an internal flyback diode, it is recommend you install a 1A 600V PIV diode in parallel with the load. (1N4005 – EC P/N 36-16-1002)
To ground ignition use pilot relay with 25 Ω 3 W series resistor to ground.
Interposing relays are recommended to interface with end devices that require high current ratings or alternative voltage supplies.
Consult General Cautions for Solid-State Devices for best practices when connecting to external inductive load devices such as relays or solenoids.
www.fwmurphy.com/other-support-resources/general-cautions-solid-state-devices

RS485 (Pins 94 – 101)

The Centurion is equipped with two RS485 communications ports. The ports are marked 94 A1 95 B1 and 100 A2 101 B2 S2. There are also two terminals, S1 SHD1 and S2 SHD2, for shield termination. The TX LED lights when the port is transmitting. The RX LED lights when the port is receiving.

The recommended arrangement of the wires is as a connected series of point-to-point (multidropped) nodes, i.e. a line or bus, not a star, ring or multiply connected network.

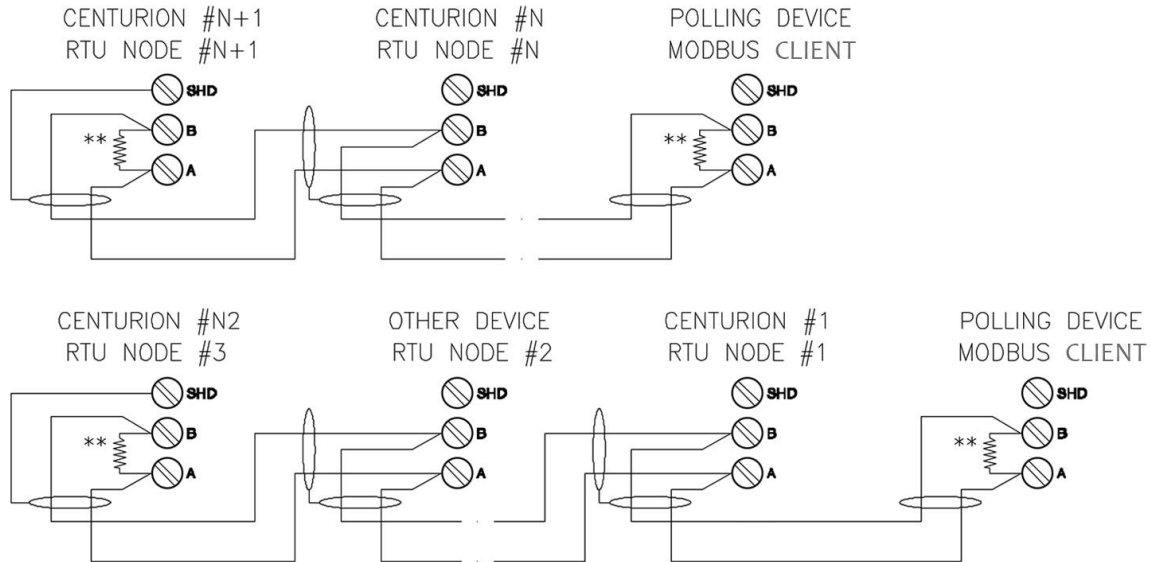

** USE EIA RS485 SHIELDED, TWISTED PAIR, 120 OHMS CHARACTERISTIC IMPEDANCE.
 INSTALL 120 OHMS TERMINATING RESISTOR ON FIRST AND LAST NODE ON RS-485 NETWORK.
 ALL RS-485 DEVICES MUST SHARE DC COMMON GROUND.

Important: For Entity Parameters or Power Supply and Grounding, refer to Wire Connections.

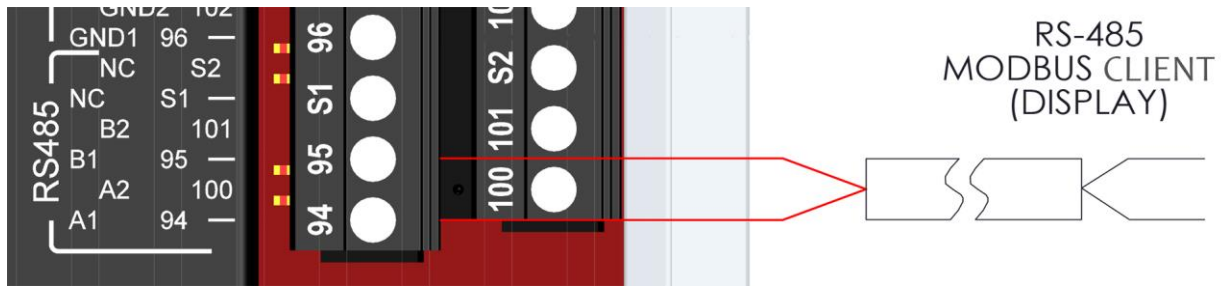

NOTE: A is the non-inverting pin and should have a single pull-up physically placed anywhere on the network. B is the inverting pin and should have a single pull-down physically placed anywhere on the network.

These circuits are not required to be in conduit if all the requirements for ic protection are met and Authority Having Jurisdiction (AHJ) allows.

Consult RS-485 the Murphy Way for information on best practices for connecting and communicating on RS-485.

www.fwmurphy.com/uploaded/documents/pdfs/rs-485murphyway.pdf

RS232 (Pins 96 – 105)

The Centurion is equipped with two RS232 communications ports. The ports are marked 96 GND1; 97 TX1; 98 RX1; 99 DTR1 and 102 GND2; 103 TX2; 104 RX2; 105 DTR2. There are also two terminals, NC and NC, that may be left unconnected or for shield termination. The LED lights when the port is active transmitting and when the port is active receiving.

Because both ends of the RS-232 circuit depend on the ground pin being zero volts, problems will occur where the voltage between the ground pin on one end and the ground pin on the other is not zero. This may also cause a hazardous ground loop. Use of a common ground limits RS-232 to applications with relatively short cables. If the two devices are far enough apart or on separate power systems, the local ground connections at either end of the cable will have differing voltages; this difference will reduce the noise margin of the signals.

Important: For Entity Parameters or Power Supply and Grounding, refer to Wire Connections.

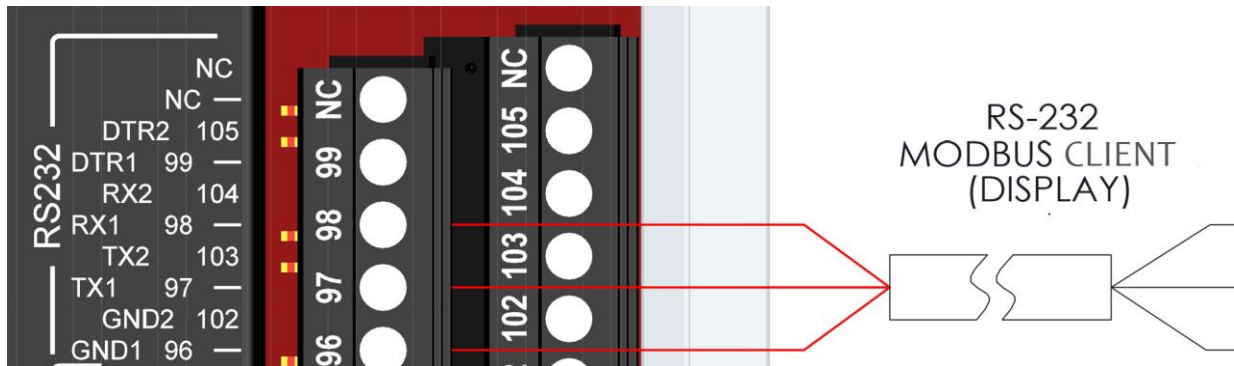

NOTE: These circuits are not required to be in conduit if all the requirements for ic protection are met and Authority Having Jurisdiction (AHJ) allows.

CAN (Pins 106 – 111)

The Centurion is equipped with two CAN communications ports. The terminals marked 106 HI1; 107 LO1 and 109 HI2; 110 LO2. There are also two terminals, 108 SHD1 and 111 SHD2 that may be used for shield termination. The LED lights when the port is active transmitting and when the port is active receiving.

The recommended arrangement of the wires is as a connected series of point-to-point (multidropped) nodes, i.e. a line or bus, not a star, ring or multiply connected network. It is recommended to use CAN bus Cable J1939/11 SAE Shielded, twisted pair, with 120 Ω characteristic impedance. Install a 120 Ω terminating resistor (software selectable on the Centurion) on the physical first and last node of the CAN network. All nodes must share a common DC ground.

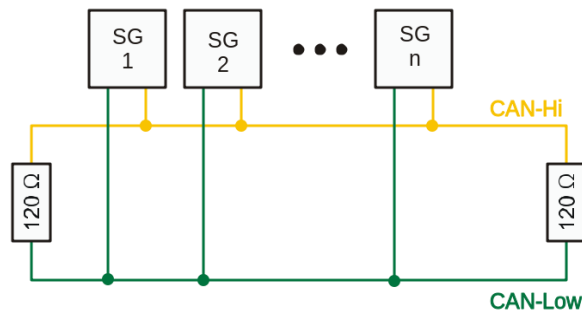

Important: For Entity Parameters or Power Supply and Grounding, refer to Wire Connections.

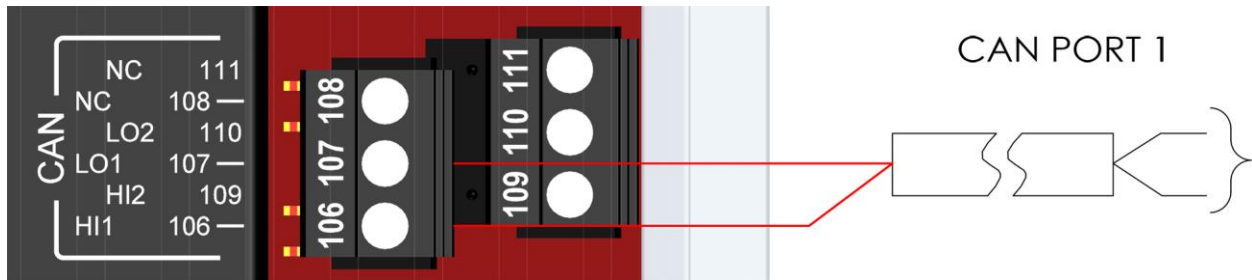

NOTE: These circuits are not required to be in conduit if all the requirements for ic protection are met and Authority Having Jurisdiction (AHJ) allows.

Modbus Address

With the Modbus RTU Server Address Configuration, the operator may assign a unique Modbus address to each controller (server) unit that may be in the system. This allows the client controller to differentiate between the modules. For example, to name the controller address 21, enable the switches labeled SW1: 1, 4, and 16 ($1 + 4 + 16 = 21$).

NOTE: The subsequent address (Address + 1) is also reserved by Centurion, and must not be used by any other device on the Modbus network, or communication failures to devices using that address will occur due to this conflict. Counting by 2's is necessary for additional Centurion controllers present in the system.



C5-1 Shown

NOTE: Typically, this configuration is set to (1) by the factory.

Ethernet



WARNING: Explosion hazard – Do not disconnect the Ethernet port unless the power has been switched off or the area is known to be non-hazardous.

The Centurion is equipped with two Ethernet communications ports. The ports are marked Ethernet 1 and Ethernet 2. An LED lights when the port is active transmitting or receiving a message, and an LED lights to indicate Network and Module status.

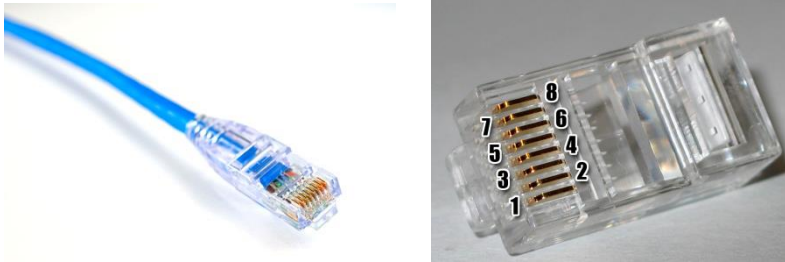

An 8P8C modular connector (often called RJ45) is commonly used on Cat 5 cables in Ethernet networks.

Twisted-pair Ethernet standards are such that the majority of cables can be wired straight-through (pin 1 to pin 1, pin 2 to pin 2 and so on), but others may need to be wired in the crossover form (receive to transmit and transmit to receive). The Centurion can automatically detect another computer connected with a straight-through cable and then automatically introduce the required crossover, if needed with no intervention by the installer. 10BASE-T and 100BASE-TX only require two pairs (pins 1-2, 3-6) to operate. Since Category 5 cable has four pairs, the spare pairs (pins 4-5, 7-8) in 10- and 100-Mbit/s configurations are not used.

TIA/EIA-568 T568A termination

Pin	Pair	Wire	Color
1	3	tip	white/green
2	3	ring	green
3	2	tip	white/orange
4	1	ring	blue
5	1	tip	white/blue
6	2	ring	orange
7	4	tip	white/brown
8	4	ring	brown

TIA/EIA-568 T568B termination

Pin	Pair	Wire	Color
1	2	tip	white/orange
2	2	ring	orange
3	3	tip	white/green
4	1	ring	blue
5	1	tip	white/blue
6	3	ring	green
7	4	tip	white/brown
8	4	ring	brown

The Centurion uses auto negotiation, an Ethernet procedure by which two connected devices choose common transmission parameters, such as speed, duplex mode and flow control. In this process, the connected devices first share their capabilities regarding these parameters and then choose the highest performance transmission mode they both support. The Centurion supports 10 and 100 Mbit/s over two-pair Cat5 or better cable.

Important: For Entity Parameters or Power Supply and Grounding, refer to Wire Connections.



C5-1 Shown

NOTE: These circuits are not required to be in conduit if all requirements for ic protection are met and Authority Having Jurisdiction (AHJ) allows.

USB 1 Host



WARNING: Explosion hazard – Do not disconnect the USB port unless the power has been switched off or the area is known to be non-hazardous.

The Centurion is equipped with a USB 2.0 standard communications port. The port is marked USB 1.

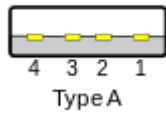

USB 1.x/2.0 standard pinout

Pin	Name	Wire color	Description
1	V _{BUS}	Red (or orange)	+5 V
2	D-	White (or gold)	Data-
3	D+	Green	Data+
4	GND	Black (or blue)	Ground

The USB 2.0 standard-A type of USB plug is a flattened rectangle that inserts into a receptacle on the USB host. The host controller directs traffic flow to devices, so no USB device can transfer any data on the bus without an explicit request from the host controller. The throughput of each USB port is determined by the slower speed of either the USB port or the USB device connected to the port.



The Centurion connects to storage devices using a set of standards called the USB mass storage device class (MSC or UMS).

Important: For Entity Parameters or Power Supply and Grounding, refer to Wire Connections.



C5-1 Shown

NOTE: These circuits are not required to be in conduit if all the requirements for ic protection are met and Authority Having Jurisdiction (AHJ) allows.

USB 2 Device



WARNING: Explosion hazard – Do not disconnect the USB port unless the power has been switched off or the area is known to be non-hazardous.

The Centurion is equipped with a USB 2.0 standard communications port. The ports is marked USB 2.

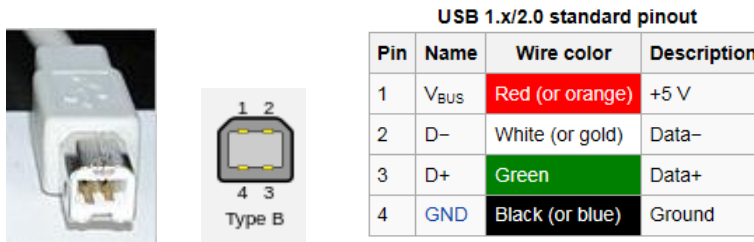

The USB 2.0 standard-B type of USB plug has a square shape with beveled exterior corners

Important: For Entity Parameters or Power Supply and Grounding, refer to Wire Connections.

When the Centurion is first connected to a USB host, the USB device enumeration process is started. The connected host controller directs traffic flow to the Centurion. There is no transfer of any data on the bus without an explicit request from the host controller.



C5-1 Shown

NOTE: These circuits are not required to be in conduit if all the requirements for ic protection are met and Authority Having Jurisdiction (AHJ) allows.

Wi-Fi (C5-1)

The Centurion C5-1 (only) is equipped with a Wi-Fi communications port. The port is marked WIFI. The Centurion allows communications directly from one computer to another without an access-point intermediary. The Wi-Fi signal range depends on the frequency band, power output, antenna gain and type. Line-of-sight is the thumbnail guide, but reflection and refraction can have a significant impact. An access point compliant with either 802.11b or 802.11g, using the stock antenna might have a range of 100 m (330 ft). Due to the complex nature of radio propagation at typical Wi-Fi frequencies, particularly the effects of signal reflection off trees and buildings, range can only be approximated for any given area in relation to a transmitter. Wi-Fi connections can be disrupted or the internet speed lowered by having other devices in the same area. Many 2.4 GHz 802.11b and 802.11g access points default to the same channel on initial startup, contributing to congestion. Wi-Fi pollution, or an excessive number of access points in the area especially on the neighboring channel, can prevent access and interfere with other devices use of other access points, caused by overlapping channels in the 802.11g/b spectrum, as well as with decreased signal-to-noise ratio (SNR) between access points.

Important: For Entity Parameters or Power Supply and Grounding, refer to Wire Connections.



C5-1 Shown

NOTE: These circuits are not required to be in conduit if all the requirements for ic protection are met and Authority Having Jurisdiction (AHJ) allows.

Accessories

Replacement Parts and Assemblies

Part Number	Description	Notes
Specify Model	C5-1 Centurion Controller (Main Module)	Centurion Configurable – Standard Centurion Custom – Option
	C5-2 Centurion Controller (Main Module)	Centurion Configurable – Standard Centurion Custom – Option
	MV-5-C display	Standard, Auto sync to C5
	MV-7T display	Optional, Auto sync to C5
	MV-10T display	
	MV-12T display	
50703852	MX4-R2 expansion I/O module	Optional
50703853	MX5-R2 expansion I/O module	
50000774	Ignition noise (choke) filter	
00032696	C5 Plug kit	Printed replacement terminal plugs for main I/O module
00032656	MX4-R2 Plug kit	Printed replacement terminal plugs for MX4-R2 expansion I/O module
00032657	MX5-R2 Plug kit	Printed replacement terminal plugs for MX5-R2 expansion I/O module
50702313	Centurion configuration tool for user application setup	Centurion configuration tool is software for modifying sequence of operation, set points, timers, faults and displays for Centurion. Includes file transfer utilities for configuration and upgrades.

Software Configuration Tool

The Centurion Configuration Tool is the configuration software for modifying sequence of operation, set points, timers, faults and displays* for Centurion C5. This tool can be downloaded from the Centurion Forum at <http://forum.fwmurphy.com>. The forum also hosts knowledge base articles and quick troubleshooting steps including those exchanged by other users. Please contact your sales personnel to gain access to the forum. In case the Centurion C5 has been custom programmed from the factory, please contact your sales channel for any modifications to the sequence of operations.

*Display configuration and other settings for display are only for use with the display Module.

Specifications

C5 Series Main I/O Module

- Operating temperature: -40° to 185° F (-40° to 85° C)
- Power input: 30 W max 10-30 VDC
- Configuration: PC-based Centurion Configuration Software
- Application firmware:
 - Standard offers a user-configurable experience
 - Centurion Custom option offers highly customized applications
 Integrate with Rockwell Automation Processors as I/O module to write IEC 61131-3 logic (Ladder Logic, Structured Text, Function Block Diagram).
- All I/O options individually software selectable: No jumper required.
- Clock: Battery backed internal real-time clock, approximately 10 years unpowered service life
- 12 Analog inputs*:
 - 0-24 mA or 0-5 VDC, 15-bit hardware
 - 4 resistive potentiometer measurement
- 32 Digital inputs*:
 - NO or NC (active high/active low) intrinsically safe
 - Optically isolated DC digital inputs (active high/active low) with LED indicators
 - Polarity sense / wire fault detection on normally closed systems
 - Approved for use with general purpose switches in hazardous areas
- Eight temperature inputs*:
 - J or K Type Thermocouples (ungrounded)
 - 3-wire 100Ω Pt RTD temperature inputs***
 - Open, short DC-, short DC+ wire fault detection
 - Cold junction compensation
- One magnetic pickup input/AC run signal:
 - 30 to 10 kHz, 4.5 VAC rms min, 40 VAC rms max.
- 10 digital outputs:
 - LED indicators:
 - 4 relay outputs, form C, dry contacts
 - 4 FET outputs (source)
 - 2 FET outputs (sink)
- Four analog outputs:
 - 4-20 mA, 16-bit hardware

- 11 Communication ports:
 - Two SERIAL RS232:
 - > Protocol: MODBUS RTU (server)
 - Two SERIAL RS485:
 - > Protocol: MODBUS RTU (server)
 - One USB: Host Type A (data log access, firmware updates)
 - One USB: Server Type B (firmware updates)
 - Two CAN:
 - > One proprietary for FW Murphy hardware
 - > One reserved for J1939 Engine ECU
 - Two Ethernet 10/100 (DLR):
 - > Protocol: Modbus TCP/IP (server)
 - > EtherNet/IP (CIP)
 - One WiFi: Optional C5-1 only
- Third-party approvals:
 - North America:
 - Class I, Div 2, Grps A,B,C,D Haz. Loc, T4
 - Class I, Zone 2, AEx ec [ic] nC IIC T4 Gc Ex ec [ic] nC IIC T4 Gc X
 - ATEX Zone 2:
 - II 3G Ex ec [ic] nC IIC T4 Gc
 - DEMKO 18 ATEX 1926X
 - 40°C ≤ Tamb ≤ +85°C
 - IECEx Zone 2:
 - Ex ec [ic] nC IIC T4 Gc
 - IECEx UL 18.0072X
 - 40°C ≤ Tamb ≤ +85°C

* Non-incendive.

** Applies only to Centurion™ Custom Applications and Rockwell Automation® Processor configurations.

*** RTD=Resistive Temperature Device, American RTD Standard, TCR 0.00392, units Ohms/Ohm / deg. between 0-100 C.

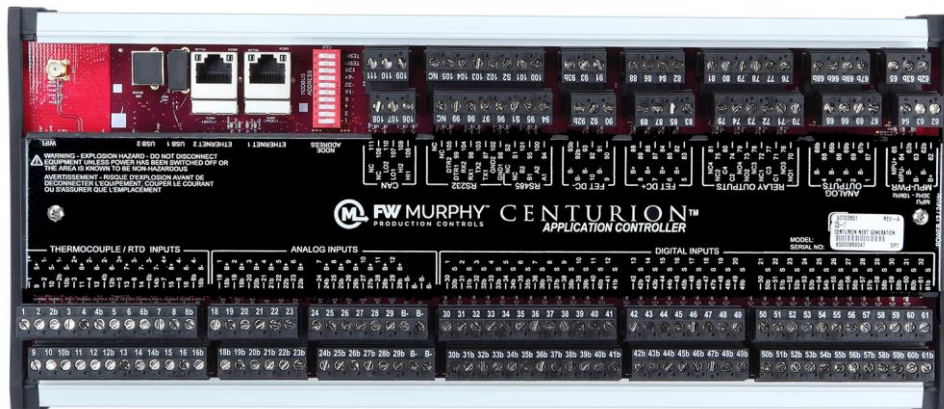

C5-1 Shown

M-View® Monochrome LCD Display

- Operating temperature: -40° to 185° F (-40° to 85° C)
- Power input: 11 W max 10-30 VDC
- Screen: 320 x 240 pixels, LCD display with backlight
- User interface: 12-key keypad set point entry, alarm acknowledgment, start, stop, reset, etc.
- Communications:
 - RS232-1/RS485-1 (MODBUS RTU client)
 - RS485-2 (MODBUS RTU server)
 - 1 USB Server Type B (firmware updates)
 - 1 USB Host Type A (reserved)
 - CAN x 2
 - >1 proprietary for FW Murphy Hardware
 - >1 reserved for J1939 engine ECU
- Customizable process screens (up to nine):
 - Line by line
 - Gage
 - Control loop
 - Generic register
- Built-in screens (examples):
 - Digital input status and polarity
 - Digital output status
 - Temperature input status/fault
 - Fault snapshot (mirror of line-by-line)
 - Alarm log
- Third-party approvals for MV-5-C Display:
 - North America:
 - Class I, Div 2, Grps A,B,C,D Haz. Loc. T4
 - Class I, Zone 2, AEx ec ic [ic] IIC T4 Gc
Ex ec ic [ic] IIC T4 Gc X
 - ATEX Zone 2:
 - Ⓔ II 3G Ex ec ic [ic] IIC T4 Gc
DEMKO 18 ATEX 1926X
-40°C ≤ Tamb ≤ +85°C
 - IECEx Zone 2:
 - Ex ec ic [ic] IIC T4 Gc
IECEX UL 18.0072X
-40°C ≤ Tamb ≤ +85°C

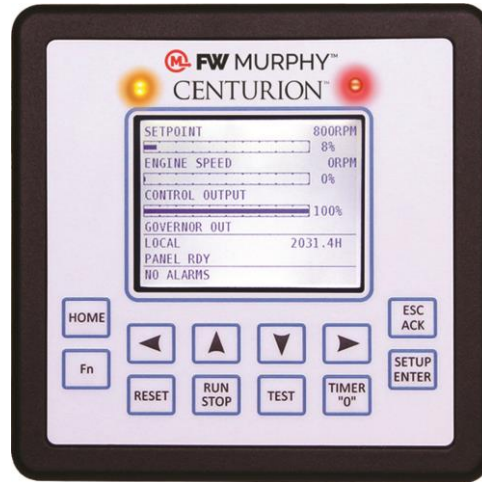

M-View® Touch Series Displays

- Operating temperature: -4° to 140° F (-20° to 60° C)
- Power input:
 - MV-7T, 15 W max 10-30 VDC (36 W max with modules)
 - MV-10T, 22 W max 10-30 VDC (52 W max with modules)
 - MV-12T, 23 W max 10-30 VDC (57 W max with modules)
- Screen (sunlight readable):
 - MV-7T, 800x480 pixels, 7" widescreen
Brightness 1000 cd/m2
 - MV-10T, 640x480 pixels, 10.4" screen
Brightness 2500 cd/m2
 - MV-12T, 1280x800 pixels, 12" widescreen
Brightness 1600 cd/m2
- User interface: resistive analog touchscreen
- Communication interface
 - 2x RS232
 - 1x RS485
 - 2x USB host type A (file transfer, data logging, USB device)
 - 1x USB server (program/firmware updates)
 - 2 Ethernet 10/100 Base TX (RJ45)
- Communication protocols:
 - EtherNet/IP (CIP)
 - Modbus TCP/IP
 - Modbus RTU standard
 - 300 plus available, web server

Third-party approvals:

CE approved

- EN 61326-1 immunity to industrial

Locations emission CISPR 11 Class A

- IEC/EN 61010-1

- RoHS compliant

ATEX approved

- II 3 G Ex ic nA IIC T4 Gc
- II 3 D Ex tc IIIC T135°C Dc
- DEMKO 14 ATEX 1387X
- EN 60079-0, -11, -15, -31

IECEX approved

- Ex ic nA IIC T4 Gc
- Ex tc IIIC T135°C Dc
- IECEX UL 15.0035X
- IEC 60079-0, -11, -15, -31

UL approved

cULus listed for ordinary location:

File #E302106

- UL 61010-1, -2-201

cULus listed for hazardous location:

File #E317425

- Class I, Division 2, Groups A, B, C and D
- Class II, Division 2, Groups F and G
- Class III, Division 2 ANSI/ISA 12.12.01, C22.2 No. 213-M1987, 157-92

IP66 Enclosure rating (Face only)

Type 4X outdoor enclosure rating (face only)

ABS type approval for shipboard applications



In order to consistently bring you the highest quality, full-featured products, we reserve the right to change our specifications and designs at any time. FW MURPHY product names and the FW MURPHY logo are proprietary trademarks. This document, including textual matter and illustrations, is copyright protected with all rights reserved. (c) 2025 FW MURPHY. A copy of our typical warranty may be viewed or printed by going to www.fwmurphy.com/warranty.

MANUFACTURING, SALES & ENGINEERING

2151 RANDON DYER ROAD
ROSENBERG, TX 77471

SALES, SERVICES & SUPPORT

4646 S HARVARD AVE
TULSA, OK 74135

DOMESTIC SALES & SUPPORT

FW MURPHY PRODUCTS
PHONE: 918 957 1000
EMAIL: INFO@FWMURPHY.COM
WWW.FWMURPHY.COM

FW MURPHY CONTROL SYSTEMS & SERVICES
PHONE: 281 633 4500
EMAIL: CSS-SOLUTIONS@DOVERPRECISION.COM

INTERNATIONAL SALES & SUPPORT

LATIN AMERICA & CARIBBEAN
PHONE: +1 918 770 8775
EMAIL: INTERNATIONAL@FWMURPHY.COM



FM 668933 (Rosenberg, TX - USA)



FW MURPHY
PRODUCTION CONTROLS

