

Interchange™ Comm Control Module, MX4-R2 Series

Installation Manual

For Models with Date Codes S8 or Higher

Warranty - A limited warranty on materials and workmanship is given with this FW Murphy product. A copy of the warranty may be viewed or printed by going to <http://www.fwmurphy.com/warranty>



**BEFORE BEGINNING INSTALLATION OF THIS FW MURPHY
PRODUCT:**

- Please read the following information before installing the MX4-R2 Module. This installation information is intended for MX4-R2 Module only.
- Visually inspect the product for any damage during shipping.
- Before proceeding please visit our website and review our support documentation including Wiring the Murphy Way www.fwmurphy.com/uploaded/WIR_Murphy_Way.pdf
- Disconnect all power and be sure machine is inoperative before beginning installation.
- Installation is to be done only by a qualified technician of the Responsible Body.
- Observe all Warnings and Cautions at each section in these instructions.
- Device shall be wired in accordance with NEC, CEC or other local code, as applicable.
- Please contact FW Murphy immediately if you have any questions.

For Class I, Division 2:

THIS EQUIPMENT IS AN OPEN-TYPE DEVICE AND IS MEANT TO BE INSTALLED IN AN ENCLOSURE SUITABLE FOR THE ENVIRONMENT SUCH THAT THE EQUIPMENT IS ONLY ACCESSIBLE WITH THE USE OF A TOOL.

THIS EQUIPMENT IS SUITABLE FOR USE IN CLASS I, DIVISION 2, GROUPS A, B, C AND D OR NON-HAZARDOUS LOCATIONS ONLY.

WARNING – EXPLOSION HAZARD – DO NOT DISCONNECT EQUIPMENT UNLESS POWER HAS BEEN REMOVED OR THE AREA IS KNOWN TO BE NON-HAZARDOUS.

WARNING – EXPLOSION HAZARD – DO NOT REPLACE BATTERIES UNLESS THE AREA IS KNOWN TO BE FREE OF IGNITABLE CONCENTRATIONS.

TEMPERATURE CODE OF T4 FOR ALL MODELS.

PROVIDES NONINCENDIVE FIELD WIRING OUTPUTS/INPUTS WHEN WIRED ACCORDING TO DRAWING 50-08-0103 (MX4-R2-X).

For AEX/EX Class I, Zone 2:

THE EQUIPMENT SHALL ONLY BE USED IN AN AREA OF POLLUTION DEGREE 2.

THE EQUIPMENT SHALL BE INSTALLED COMPLETELY WITHIN AN ENCLOSURE THAT PROVIDES A MINIMUM INGRESS PROTECTION OF IP 54 IN ACCORDANCE WITH UL60079-0 AND ONLY ACCESSIBLE BY THE USE OF A TOOL.

THE WIRE SIZE, TORQUE RATING OF 12-24 AWG, 0.37-0.44 ft. lbs.(0.4-0.5 Nm), AND SUITABLE SUPPLY WIRE TEMPERATURE RATING OF 97°C MINIMUM SHALL BE PROVIDED FOR THE INPUT POWER TERMINAL BLOCK.

ALL MARKING INFORMATION EXCEPT FOR SERIAL NUMBER/DATE CODES SHALL BE REPEATED.

PROVIDES NONINCENDIVE FIELD WIRING OUTPUTS/INPUTS WHEN WIRED ACCORDING TO DRAWING 50-08-0103 (MX4-R2-X).

SPECIAL CONDITIONS FOR USE IECEx/ATEX Zone 2:

THE EQUIPMENT SHALL ONLY BE USED IN AN AREA OF NOT MORE THAN POLLUTION DEGREE 2, AS DEFINED IN IEC/EN 60664-1.

THE EQUIPMENT SHALL BE INSTALLED IN AN ENCLOSURE THAT PROVIDES A DEGREE OF PROTECTION NOT LESS THAN IP 54 IN ACCORDANCE WITH IEC/EN 60079-0 AND ONLY ACCESSIBLE BY THE USE OF A TOOL.

THIS PAGE INTENTIONALLY LEFT BLANK

Table of Contents

FW Murphy Interchange Comm Control Module Series	1
Accessories.....	1
Specifications.....	1
Installation	2
Dimensions.....	2
Install MX4-R2 Module.....	3
Wire Connections	4
Wire Diagram — MX4-R2 Module.....	4
Entity Parameters.....	5
Thermocouple / RTD Inputs (Pins 1 – 36 and 55 – 58).....	8
Power (Pins 37 – 38).....	9
Magnetic Pickup, MPU (Pins 41 – 42).....	10
RS485 (Pins 49 – 50).....	11
CAN (Pins 52 – 53).....	13
DIP Switch Configuration.....	14
Ethernet.....	15
Communications for Standard IO Application Mode (default)	17
Communications for Rockwell Automation IO Mode	18

THIS PAGE INTENTIONALLY LEFT BLANK

FW Murphy Interchange Comm Control Module Series

The MX4-R2 expansion module provides temperature and frequency input capability to the Centurion and future generations of FW Murphy Controllers using CAN proprietary communication with enhanced diagnostics. A serial RS485 port and 2 Ethernet ports also provide communication methods to work with any Modbus RTU or TCP/IP client device. MX4-R2 is backward compatible with MX4. Load Rockwell IO Application for EtherNet/IP (CIP) Protocol function.

Accessories

MX4-R2 Plug Kit (00032656) Printed Terminal Plugs for MX4-R2 Expansion I/O Module

Specifications

- Operating temperature: -40° to 185° F (-40° to 85° C)
- Power input: 14.1 W max 10-30 VDC
- All input options individually software selectable.
- 18* temperature inputs:
 - J or K Type Thermocouples (ungrounded)
 - Cold junction compensation
- 9* 3-wire 100Ω Pt RTD temperature inputs**
- Open circuit, short DC-, short DC+ wire fault detection
- One magnetic pickup input*/AC run signal
 - 30 Hz to 10 kHz
- 4 Communication ports:
 - Serial RS485
 - Protocol: MODBUS RTU (server)
 - CAN
 - Protocol: Proprietary for FW Murphy hardware
 - Two Ethernet 10/100 (DLR), Single MAC ID:
 - Protocol: Modbus TCP/IP (server) standard or Ethernet/IP (CIP) in Rockwell IO Application Mode
- Third-party approvals for MX4-R2:
 - Class I, Div 2, Grps A, B, C, D Haz. Loc. T4
 - Class I, Zone 2, AEx ec [ic] IIC T4 Gc
Ex ec [ic] IIC T4 Gc X
 - ATEX Zone 2:
 -  II 3G Ex ec [ic] IIC T4 Gc
 - DEMKO 18 ATEX 1926X
 - -40°C ≤ Tamb ≤ +85°C
 - IECEx Zone 2:
 - Ex ec [ic] IIC T4 Gc
 - IECEx UL 18.0072X
 - -40°C ≤ Tamb ≤ +85°C

* Non-incendive. Temperature Inputs are intrinsically safe and non-incendive.

** RTD=Resistive Temperature Device, American RTD Standard, TCR 0.00392, units Ohms/Ohm / deg. between 0-100 C.

NOTE: For each channel that is selected as RTD, 2 thermocouple channels are used and no longer available as thermocouple channels.

Installation

Dimensions

Measurements are (mm).

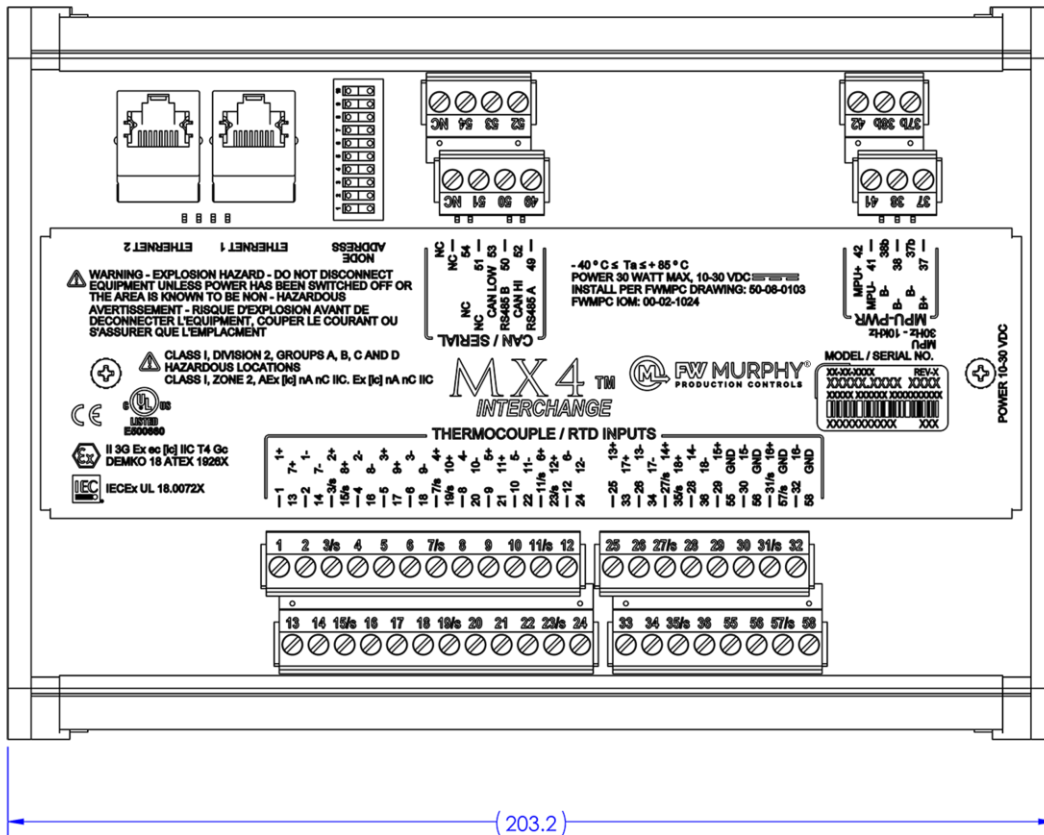
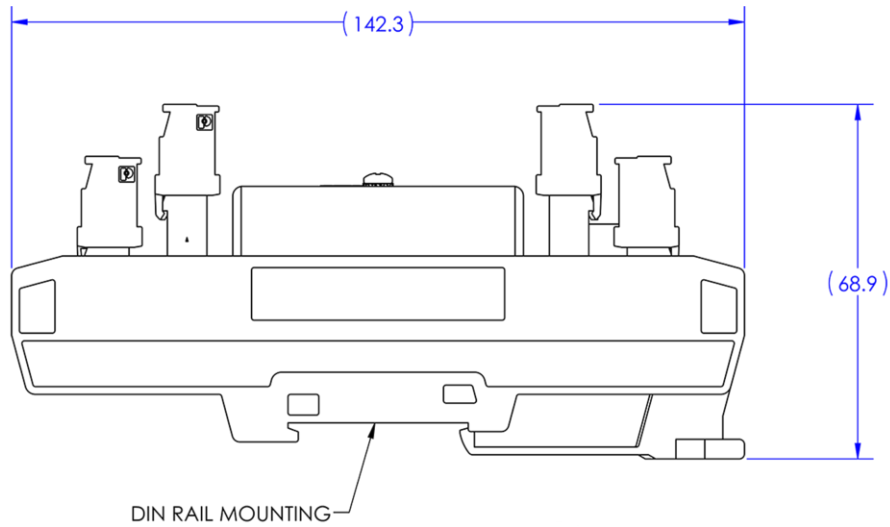

MX4-R2 Module Installation

The MX4-R2 must be mounted in an enclosure meeting the requirements of IP54 or greater according to the intended use and environmental conditions in accordance with standard UL and only accessible by use of a tool.

NOTE: IP requirement is ONLY for North America and IECEx/ATEX Zones UL 60079, IEC/EN 60079-0.

- Operating Temperature -40° to 185° F (-40° C to +85° C)
- Pressure 80 kPa (0,8 bar) to 110 kPa (1,1 bar)
- Air with normal oxygen content, typically 21% v/v
- Temperature Class T4
- “ic”: intrinsic safety (for EPL Gc)
- Increased safety (for EPL Gc)

The MX4-R2 can be mounted vertically or horizontally on a standard DIN rail. Three clamp-type feet along the bottom of the controller attach to the DIN rail; however, rail stops are recommended to prevent sliding.

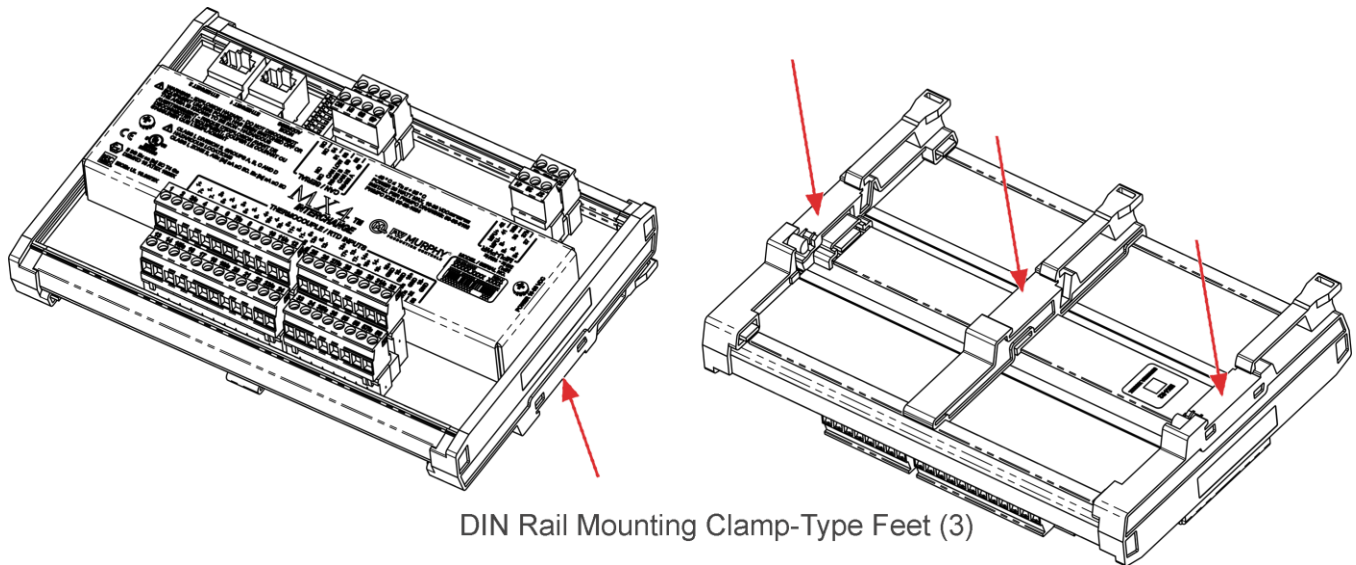

Wire Connections

Wire Diagram — MX4-R2 Module

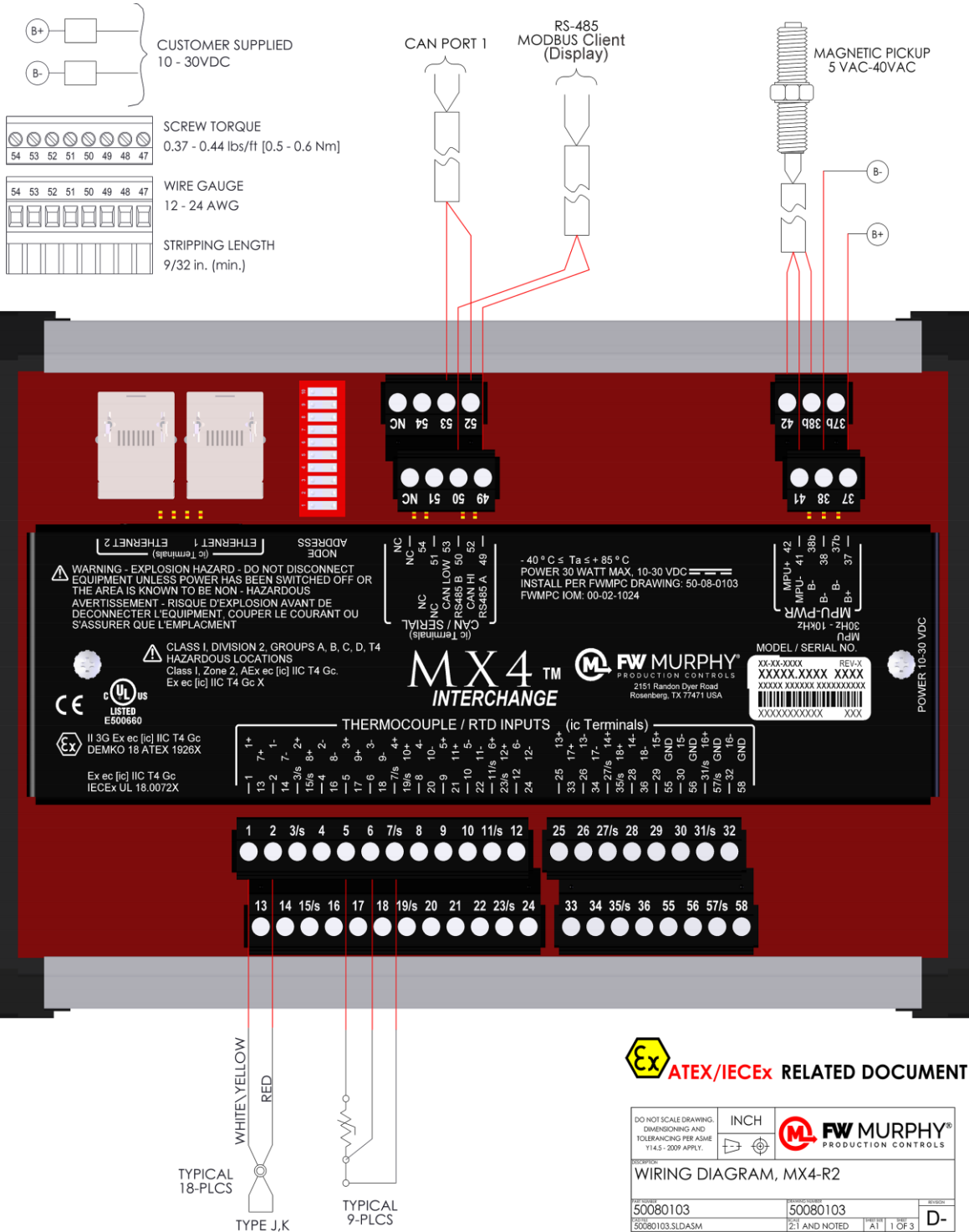

Entity Parameters

- The output current of this associated apparatus is limited by a resistor such that the output voltage-current plot is a straight line drawn between open-circuit voltage and short-circuit current. The Entity Concept allows interconnection of intrinsically safe apparatus with associated apparatus not specifically examined in combination as a system when the approved values of V_{oc} (or U_o) and I_{sc} (or I_o) for the associated apparatus are less than or equal to V_{max} (U_i) and I_{max} (I_i) for the intrinsically safe apparatus. Capacitance and inductance of the field wiring from the intrinsically safe equipment to the associated apparatus shall be calculated and must be included in the system calculations. Cable capacitance, C_{cable} , plus intrinsically safe equipment capacitance, C_i must be less than the marked capacitance, C_a (or C_o), shown on any associated apparatus used. The same applies for inductance (L_{cable} , L_i and L_a or L_o , respectively). Where the cable capacitance and inductance per foot are not known, the following values shall be used: $C_{cable} = 60$ pF/ft., $L_{cable} = 0.2$ μ H/ft.

<p>Hazardous (Classified) Location Class I, Div 2 Grps A, B, C and D Class I, Zone 2, Group IIC IECEX/ATEX Zone 2, Group IIC</p>	<p>Nonhazardous Location or Hazardous (Classified) Location Class I, Div 2 Grps A, B, C and D Class I, Zone 2, Group IIC IECEX/ATEX Zone 2, Group IIC</p>
--	---

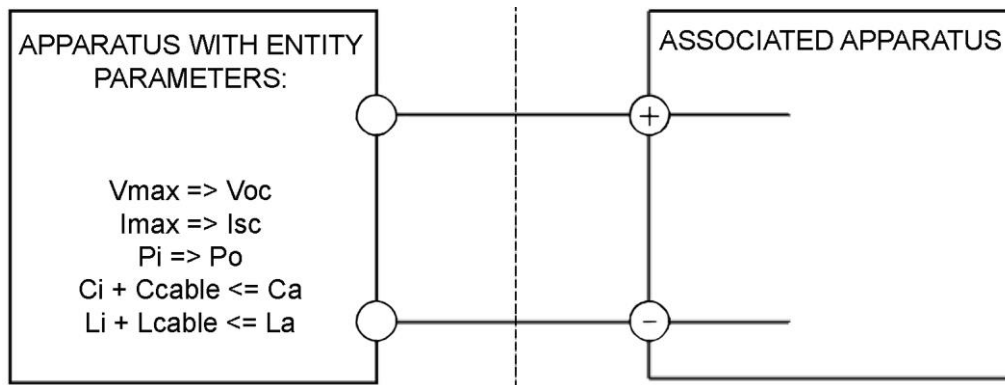

$$U_i \geq U_o; I_i \geq I_o; C_o \geq C_i + C_{cable}; L_o \geq L_i + L_{cable}$$

- This associated apparatus may also be connected to non-incendive or simple apparatus as defined in Article 504.2 and installed and temperature classified in accordance with Article 504.10 (B) of the National Electrical Code (ANSI/NFPA 70) or other local codes, as applicable. Examples of "simple apparatus" are general-purpose contact/switch, thermocouples and RTD.

3. For Intrinsically Safe devices selected associated apparatus must be third-party listed as providing intrinsically safe circuits for the application or have V_{oc} or V_t not exceeding V_{max} (or U_o not exceeding U_i), I_{sc} or I_t not exceeding I_{max} (or I_o not exceeding I_i), and the P_o of the associated apparatus must be less than or equal to the P_{max} or P_i of the intrinsically safe equipment. Examples of “simple apparatus” are general-purpose contact/switch, thermocouples and RTD.
4. Where multiple circuits extend from the same piece of associated apparatus, they must be installed in separate cables or in one cable having suitable insulation. Refer to Article 504.30(B) of the National Electrical Code (ANSI/NFPA 70) and Instrument Society of America Recommended Practice ISA RP12.6 for installing intrinsically safe equipment.
5. Intrinsically safe circuits must be wired and separated in accordance with Article 504.20 of the National Electrical Code (ANSI/NFPA 70) or other local codes, as applicable.
6. This associated apparatus has not been evaluated for use in combination with another associated apparatus.
7. Control equipment must not use or generate more than 250 V rms or dc with respect to earth.
8. For installations in which both the C_i and L_i of the intrinsically safe apparatus exceeds 1% of the C_o and L_o parameters of the associated apparatus (excluding the cable), then 50% of C_o and L_o parameters are applicable and shall not be exceeded.



WARNING:

EXPLOSION HAZARD - DO NOT DISCONNECT EQUIPMENT UNLESS POWER HAS BEEN SWITCHED OFF OR THE AREA IS KNOWN TO BE NON-HAZARDOUS.

AVERTISSEMENT - RISQUE D'EXPLOSION - AVANT DE DECONNECTER L'EQUIPEMENT, COUPER LE COURANT OU S'ASSURER QUE L'EMPLACEMENT EST DESIGNÉ NON DANGEREUX.

Entity Parameters (continued)

Thermocouple/RTD Inputs (Per Pin) J1-J2										
Designation	Uo[V]	Io[mA]	Po[mW]	Lo[H]	Co[μF]	Ui[V]	Ii[mA]	Pi[mW]	Li[mH]	Ci[μF]
Pins 2, 4, 6, 8, 10, 12, 14, 16, 18, 20, 22, 24, 26, 28, 30, 34, 36,	4.4	1.0	4.4	80	999.9	30	17.0	-	0	0.1
Pins 1, 3/s, 5, 7/s, 9, 11/s, 13, 15, 17, 19/s, 21, 23/s, 25, 27/s, 29, 31/s, 32, 33, 35/s	4.4	1.0	4.4	80	995.1	30	17.0	-	0.022	4.9
J2 Pin 55, 56, 57, 58	Thermocouple/RTD Inputs Ground									

RS485/CAN											
Designation	Uo[V]	Io[mA]	Po[mW]	Lo[mH]	Co[μF]	Ui[V]	Ii[mA]	Pi[mW]	Li[mH]	Ci[μF]	Ci[pF]
J4 RS485 Pins 49, 50	±5.0	±60	-	22.2	999.9	±12.0	±60	-	0	0.01	-
J4 RS485 Pin 51	Shield Connection Ground										
J4 CAN Pins 52, 653	±4.5	±5	-	3.2	999.9	±24	100	-	0	-	267
J4 CAN Pin 54	Shield Connection Ground										

MPU – Entity Parameters											
Designation	Type of Protection	Uo [V]	Io [mA]	Po [mW]	Lo [mH]	Co [μF]	Ui [V]	Ii [mA]	Pi [W]	Li [mH]	Ci [μF]
38b, 41 Pins	nA	-	-	-	0	0	-	-	-	-	-
42 Pin	nA	-	-	-	0.00075	-	40Vrms	0.001	0.12	-	-

Ethernet Per Port										
Designation	Uo[V]	Io[mA]	Po[mW]	Lo[mH]	Co[μF]	Ui[V]	Ii[mA]	Pi[mW]	Li[mH]	Ci[μF]
J5-J6	3.3	±61.5	-	21.2	999.9	3.3	±60	-	0	0.1

Thermocouple / RTD Inputs (Pins 1 – 36 and 55 – 58)

The MX4-R2 is equipped with 18 two-wire thermocouple and/or 9 three-wire RTD inputs.

Thermocouples are wired using cover artwork labeled as + and -, such as 1+ and 1-. Thermocouples terminals can be seen labeled as 1 and 2 for TC 1 channel and 3 and 4 for TC 2 channel and so on. Use ungrounded thermocouples only, grounded thermocouples are not supported.

When RTD is selected for the channel, 3 terminals are required. RTDs are wired using cover artwork labeled with the same + and - but also includes a /s for the sense lead. This terminal is also the + (plus) for the adjacent channel.

Therefore, the adjacent channel is no longer available as thermocouple and is disabled.

RTD's terminals can be seen labeled in the as 1,2,3/s for the first channel and 5,6,7/s for the next channel and so on skipping the - (minus) terminal from the adjacent channel.

Important: For Entity Parameters or Power Supply and Grounding, refer to Wire Connections.

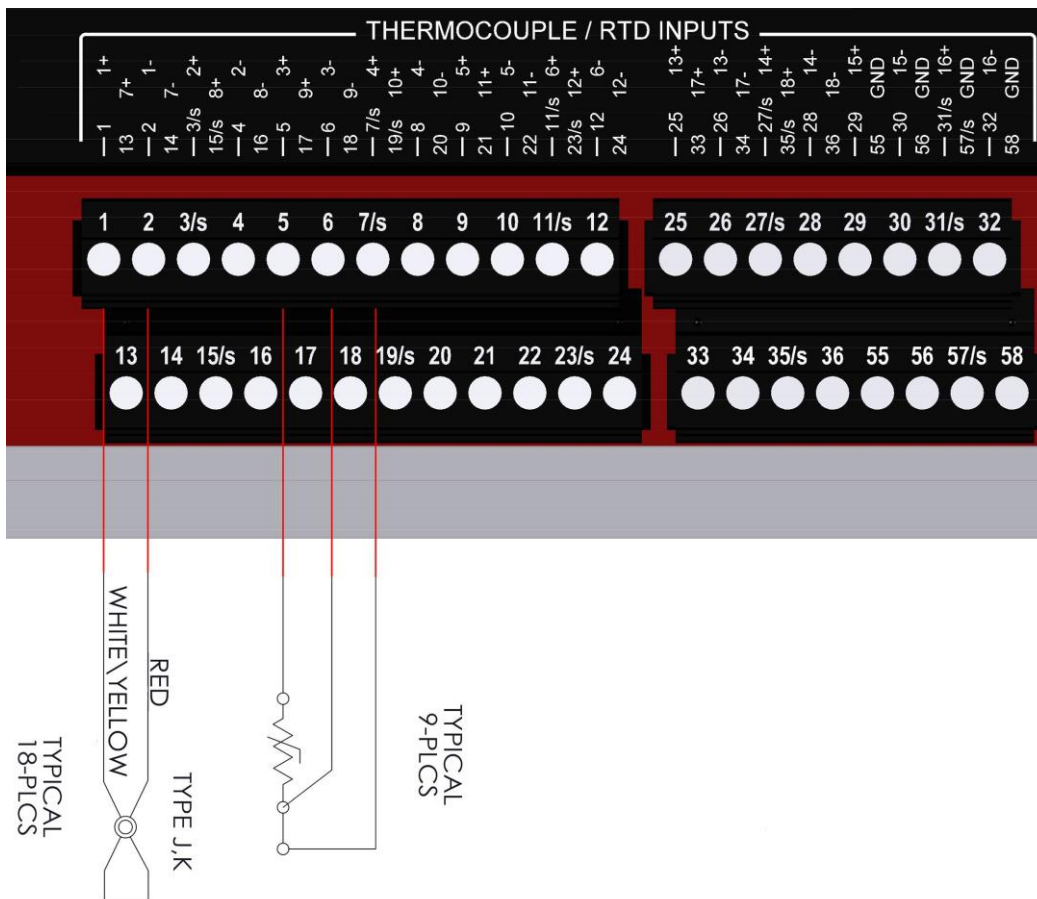

NOTE: These circuits are not required to be in conduit if all the requirements for ic protection are met and Authority Having Jurisdiction (AHJ) allows.

Power (Pins 37 – 38)

The 10-30 VDC power for the MX4-R2 is applied to the power supply terminals marked 37 B+ and 38 B-. An external 10-amp replaceable fuse protects the system from over-currents, and a power LED lights when power is applied to the system.

Important: For Entity Parameters or Power Supply and Grounding, refer to Wire Connections.

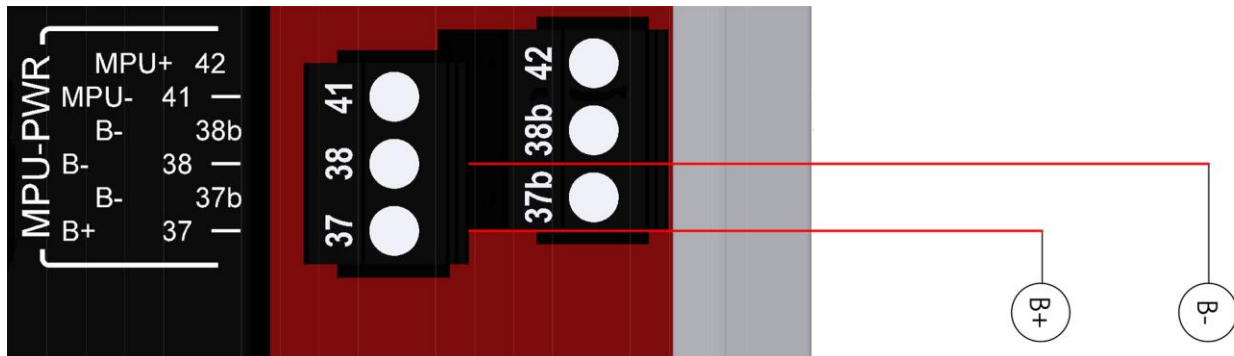

NOTE: Run power directly from battery posts to controller power terminals when battery is the power supply.

Maximum power ratings based on all I/O operating in the ON position with 10V supply. Typically based on 24V supply.

Magnetic Pickup, MPU (Pins 41 – 42)

The MPU for the MX4-R2 is applied to the magnetic pickup terminals marked 41 MPU- and 42 MPU+, MPU 5-40 Vrms 30-10 kHz. If used, the foil shield and drain wire of the cable assembly may be terminated at 37b- or 38b-. The MPU sends the pulses to the controller, which calculates the engine speed.

FW Murphy recommends using 00031022 Magnetic Pickup 4 in. Length and 00031023 Magnetic Pickup Cable 50 ft.

Important: For Entity Parameters or Power Supply and Grounding, refer to Wire Connections.

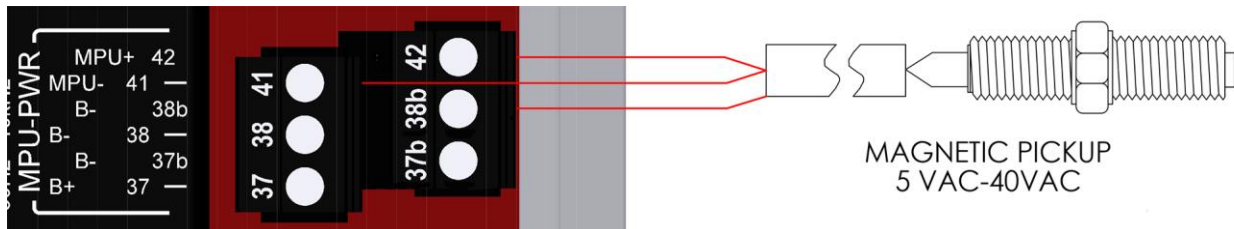

NOTE: The MPU input requires a minimum signal of 2 Vrms when connected.

RS485 (Pins 49 – 50)

The MX4-R2 is equipped with RS485 communications ports 49 A / 50 B.

The TX LED lights when the port is transmitting. The RX LED lights when the port is receiving.

Important: For Entity Parameters or Power Supply and Grounding, refer to Wire Connections.

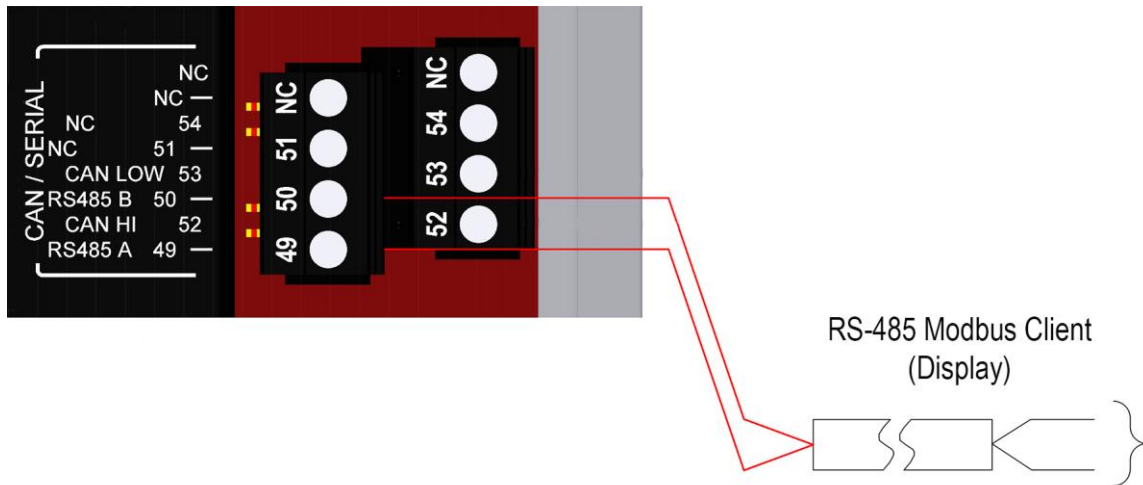

NOTE: A is the non-inverting pin and should have a single pull-up physically placed anywhere on the network. B is the inverting pin and should have a single pull-down physically placed anywhere on the network.

These circuits are not required to be in conduit if all the requirements for ic protection are met and Authority Having Jurisdiction (AHJ) allows.

Consult RS-485 the Murphy Way for information on best practices for connecting and communicating on RS-485.

www.fwmurphy.com/uploaded/documents/pdfs/rs-485murphyway.pdf

The recommended arrangement of the wires is as a connected series of point-to-point (multidropped) nodes, i.e. a line or bus, not a star, ring or multiply connected network.

RS-485 Typical Connections

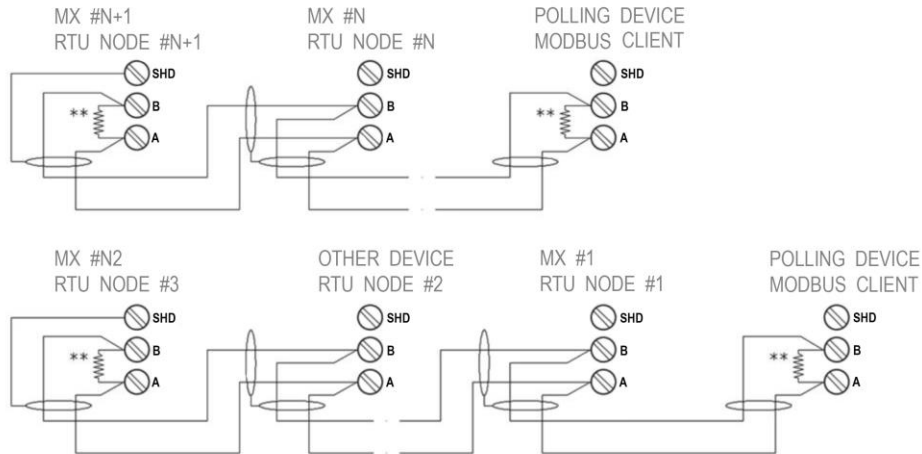

** USE EIA RS485 SHIELDED, TWISTED PAIR, 120 OHMS CHARACTERISTIC IMPEDANCE.
 INSTALL 120 OHMS TERMINATING RESISTOR ON FIRST AND LAST NODE ON RS-485 NETWORK.
 ALL RS-485 DEVICES MUST SHARE DC COMMON GROUND.

CAN (Pins 52 – 53)

The MX4-R2 is equipped with a CAN communication port. The port is marked pin 52 CAN HI and pin 53 CAN LOW.

The LED lights when the port is active transmitting and when the port is active receiving.

The recommended arrangement of the wires is as a connected series of point-to-point (multidropped) nodes, i.e. a line or bus, not a star, ring or multiply connected network. We recommend using CAN-Bus Cable J1939/11 SAE Shielded, twisted pair with 120 Ω characteristic impedance. Install a 120 Ω terminating resistor (DIP switch controls this on the MX4-R2) on the physical first and last node of the CAN network. All nodes must share a common DC ground

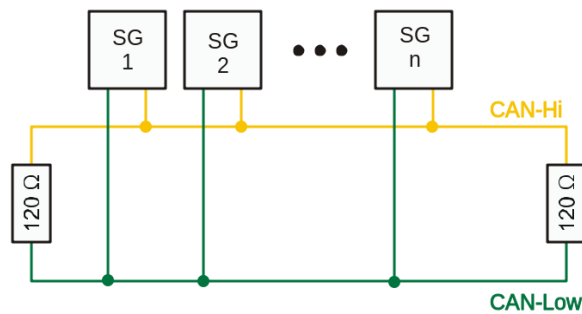

Important: For Entity Parameters or Power Supply and Grounding, refer to Wire Connections.

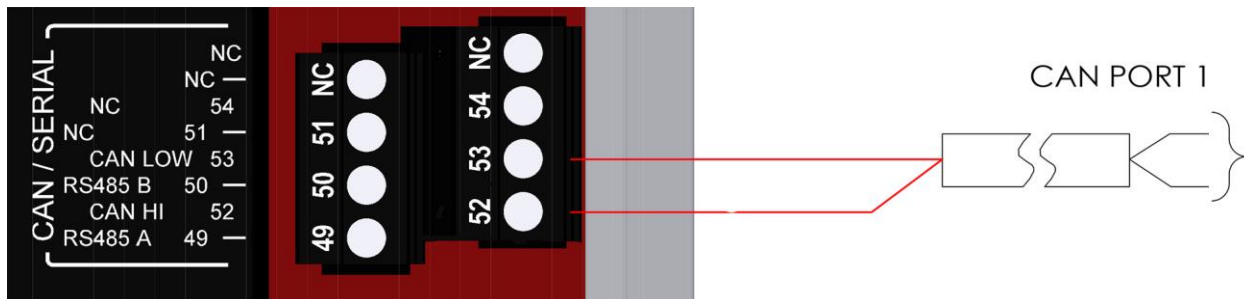

NOTE: These circuits are not required to be in conduit if all the requirements for ic protection are met and Authority Having Jurisdiction (AHJ) allows.

DIP Switch Configuration

Set these switches to the open or closed position for your application.

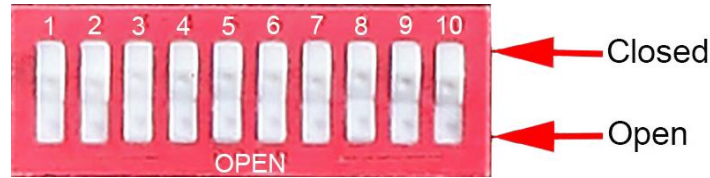

Modbus Server Node Address:

- **DIP1-8:** These switches allow you to assign a unique address to each MX4-R2 that may be in the system using either Modbus or CAN communication. This allows the client controller to differentiate between the modules. Addressing is done in binary format, with each switch increasing value by factor of 2. For example, to name the controller address 5, set switch DIP1 and DIP4 to the CLOSED position. Valid settings are from 1 to 239. Addresses 240 thru 255 are reserved for power up functions. See Operations Manual.

CAN Termination:

- **DIP9:** This switch provides a 120Ω termination resistor for the CAN communication chain. CAN must be wired in a daisy chain configuration. Set this switch to CLOSED only when the module is the end of the network. See control panel drawings for designation.

RS485 Termination:

- **DIP10:** This switch provides a 120Ω termination resistor for the RS485 communication chain. RS485 must be wired in a daisy chain configuration. Set this switch to CLOSED only when the module is the end of the network. See control panel drawings for designation.

Ethernet

The MX4-R2 is equipped with two Ethernet communication ports. The ports are marked ETHERNET 1 and ETHERNET 2. An LED flashes when the port is active — transmitting or receiving a message, and an LED lights to indicate the link is active when connected to another device. LED closest to the DIP switch illuminates for 100Mbit connections. LED furthest from the DIP switch illuminates for 10Mbit connections.



WARNING: Explosion hazard – Do not disconnect the Ethernet port unless the power has been switched off or the area is known to be non-hazardous.

Below is an 8P8C modular connector (often called RJ45) commonly used on Cat 5 cables in Ethernet networks.

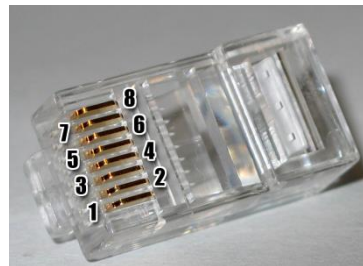
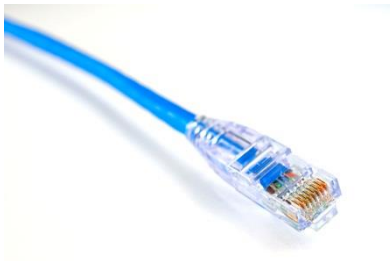

Twisted-pair Ethernet standards are such that the majority of cables can be wired "straight-through" (pin 1 to pin 1, pin 2 to pin 2 and so on), but others may need to be wired in the "crossover" form (receive to transmit and transmit to receive). The MX4-R2 can automatically detect another computer connected with a straight-through cable and then automatically introduce the required crossover, if needed with no intervention by the installer. 10BASE-T and 100BASE-TX only require two pairs (pins 1-2, 3-6) to operate. Since Category 5 cable has four pairs, the spare pairs (pins 4–5, 7–8) in 10- and 100-Mbit/s configurations are not used.

TIA/EIA-568 T568A termination

Pin	Pair	Wire	Color
1	3	tip	 white/green
2	3	ring	 green
3	2	tip	 white/orange
4	1	ring	 blue
5	1	tip	 white/blue
6	2	ring	 orange
7	4	tip	 white/brown
8	4	ring	 brown

TIA/EIA-568 T568B termination

Pin	Pair	Wire	Color
1	2	tip	 white/orange
2	2	ring	 orange
3	3	tip	 white/green
4	1	ring	 blue
5	1	tip	 white/blue
6	3	ring	 green
7	4	tip	 white/brown
8	4	ring	 brown

The MX4-R2 uses autonegotiation, an Ethernet procedure by which two connected devices choose common transmission parameters, such as speed, duplex mode and flow control. In this process, the connected devices first share their capabilities regarding these parameters and then choose the highest performance transmission mode they both support. The MX4-R2 supports 10 and 100 Mbit/s over two-pair Cat5 or better cable.

Important: For Entity Parameters or Power Supply and Grounding, refer to Wire Connections.

NOTE: These circuits are not required to be in conduit if all the requirements for ic protection are met and Authority Having Jurisdiction (AHJ) allows.

Communications for Standard IO Application Mode (default)

Physical Layer: The MX4-R2 module features two Ethernet ports, one RS485 serial communication port and one CAN bus 2.0B communication port.

Ethernet Interconnect: Two RJ45 jacks with single MAC ID. This connection may require setting the IP address of the module to the desired network configuration. Ethernet port settings can be changed by modifying Modbus registers. Default setting is 192.168.0.100 IP, 255.255.255.0 network mask, 0.0.0.0 Gateway.

Ethernet Protocol: Modbus TCP/IP server. Refer to the Modbus RTU map provided in this manual for a detailed mapping of the available data and data scaling.

Serial RS485 Interconnect: Screw terminals. Typically, this connection uses twisted shielded pair cable with 120-ohm impedance. RS485 networks are 2-wire, half-duplex and feature an “A” terminal 49 and “B” terminal 50. The A terminal is the + or non-inverting signal, and the B terminal is the – or inverting signal. These signal lines will take turns transmitting and receiving depending on the device using the RS485 network at any given instant.

Serial Baud Rate: Default 9600, adjustable up to 115.2k.

Serial Stop Bits: The module will respond with 1 stop bit for Modbus RTU addresses 1 through 31 and 2 stop bits for addresses 32 through 239. This maintains flexibility for systems requiring 2 stop bits.

Serial Protocol: Modbus RTU server. The module may be polled by the Modbus RTU Client without any additional timing delays and response times will be < 100mS. This may vary depending on the amount of data requested. Modbus RTU timeout settings should be set to >= 400mS.

Refer to the Modbus RTU map provided in this manual for a detailed mapping of the available data and data scaling.

CAN bus Interconnect: Screw terminals. Typically, this connection uses twisted pair cable with 120-ohm impedance to connect to a FW Murphy Controller. CAN bus networks are 2-wire with a “HI” terminal 52 and “LOW” terminal 53.

CAN bus Baud Rate: 250kbit/500kbit/1000kbit auto sense.

CAN bus Protocol: Proprietary for FW Murphy Controllers.

PC Connection: Reading data from the module into a PC may be done with an Ethernet connection and Modbus TCP/IP client software or RS485 connection and Modbus RTU client software. A serial interface converter that can convert USB to RS485 would be needed for a serial connection. (FW Murphy MConfig™ Software and P/N 53702325 may be used for this purpose.)

Communications for Rockwell Automation IO Mode

Physical Layer: The MX4-R2 module features two Ethernet ports.

Ethernet Interconnect: Two RJ45 jacks with Single MAC ID. This connection may require setting the IP address of the module to the desired network configuration. Ethernet port settings can be changed by modifying Modbus registers. Default setting is 192.168.0.100 IP, 255.255.255.0 network mask, 0.0.0.0 Gateway.

Ethernet Protocol: CIP for use with Rockwell Automation IO.

In order to consistently bring you the highest quality, full-featured products, we reserve the right to change our specifications and designs at any time. FW MURPHY product names and the FW MURPHY logo are proprietary trademarks. This document, including textual matter and illustrations, is copyright protected with all rights reserved. (c) 2025 FW MURPHY. A copy of our typical warranty may be viewed or printed by going to www.fwmurphy.com/warranty.

MANUFACTURING, SALES & ENGINEERING
2151 RANDON DYER ROAD
ROSENBERG, TX 77471

SALES, SERVICES & SUPPORT
4646 S HARVARD AVE
TULSA, OK 74135

DOMESTIC SALES & SUPPORT
FW MURPHY PRODUCTS
PHONE: 918 957 1000
EMAIL: INFO@FWMURPHY.COM
WWW.FWMURPHY.COM

FW MURPHY CONTROL SYSTEMS & SERVICES
PHONE: 281 633 4500
EMAIL: CSS-SOLUTIONS@DOVERPRECISION.COM

INTERNATIONAL SALES & SUPPORT
LATIN AMERICA & CARIBBEAN
PHONE: +1 918 770 8775
EMAIL: INTERNATIONAL@FWMURPHY.COM



FM 668933 (Rosenberg, TX - USA)



FW MURPHY
PRODUCTION CONTROLS

