

# Level Maintainer

## LM300 Series

The LM300 Series Level Maintainer automatically adds oil to the crankcase as needed to keep the lube level normal. Most models have built-in switches that will alarm and/or shut down the equipment if the makeup supply is depleted and engine oil level falls or if overfill conditions exist. The LM300 can be used in engines, compressors, pumps and coolers.

The LM300 Series EX models (explosion-proof) are CSA certified for Class I, Division 1 Hazardous areas.

### Specifications

**Case/Cover:** Die cast aluminum

**Switch Housing:** Aluminum

**Approval Rating:** All CSA Certified with switch contacts rated at 10 A at 250 VAC (standard)

**LM301 through LM305:**

CSA certified for non-hazardous locations. Enclosure Type 4 certified.

**LM301-EX through LM303-EX:**

CSA certified for Class I, Groups C and D; Class II, Groups F and G hazardous locations. Enclosure Type 4 certified.

**Float:** Rigid polyurethane foam; Polyurethane coated

**Max. Ambient Temperature:** 250° F (121° C)

**Oil Inlet Connection:** Top entry 1/2-14 NPT with built-in filter screen (removable for cleaning)

**Inlet Orifices:** 1/4 in. (6 mm) standard; 1/8 in. (3 mm) available

**Wire (switch models):** 18 AWG x 13 in. (1.0 mm<sup>2</sup> x 330 mm)

**Max. Inlet Pressure (MIP):**

30 psi (207 kPa) [2.07 bar] with 1/8 in. (3 mm) orifice  
15 ft oil (4.6 m oil) with 1/4 in. (6 mm) orifice

**Max. Differential:** 2 in. (51 mm) between running and stationary oil level

**Max. Case Pressure (MCP):** 15 psi (103 kPa) [1.03 bar]

**Orifice Seal:** Buna-N Thumb-Valve

**Switch Contact:** Silver, SPDT snap-acting, rated at 10 A @ 125, 250 VAC; 10 A @ 30 VDC (1 only for low level; 2 only for high and low; or 2 only for low level with alarm before shutdown)

**Outlet Connection:** 3/4-14 NPT left side, right side and bottom

**Crankcase Balance Vent Fitting:** 1/2-14 NPT

**Mounting:** Accepts FW Murphy pipe or universal mounting brackets

**Lens:** Clear Frog Eye non-staining, high-impact, high-temperature nylon; UV and heat stabilized

**Glass Lens:** Available on LM301 and LM301-EX models. Specify GL as part of model number when ordering

**Dial:** High visibility white background with green and white index lines for normal level indication

**Test Knob:** Rotate to test switch operation. Turn clockwise for low level test and turn counterclockwise for high level test.

Flow Rate Test Using SAE 30 @ 32° F (0° C)		
Orifice Diameter	Pressure	Flow Rates
1/4 in. (6 mm) (Standard)	4 ft. oil - 15 ft. oil (1.2 m oil - 4.6 m oil)	4.7 GPH - 31.0 GPH (17.8 LPH - 117.3 LPH)
1/8 in. (3 mm)	10 psig - 30 psig (68.9 kPa - 207 kPa) [.69 - 2.07 bar]	16.9 GPH - 32.1 GPH (63.7 LPH - 121.5 LPH)

**NOTE:** Friction losses due to piping not considered

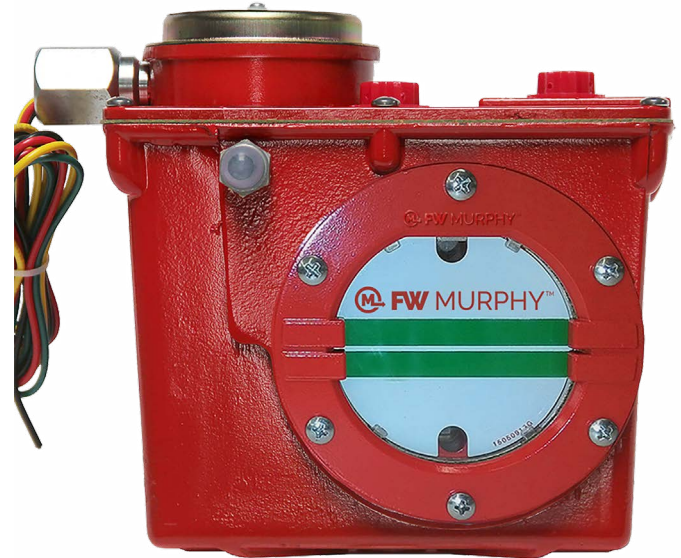

\*Products covered by this bulletin comply with Directive: 2004/108/EC (European Electromagnetic Compatibility). European Harmonised standard: EN 61000-6-3:2007 (Emissions), EN 61000-6-1:2005 (Immunity)

### Dimensions

Explosion-proof model shown.

Non-explosion proof models are smaller in height and width 7 in. (178 mm) H, 7-7/8 in. (200 mm) W.

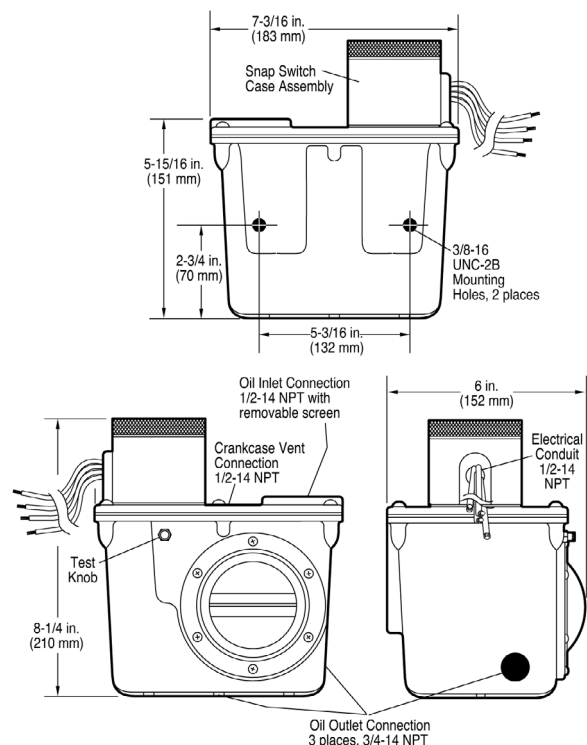

# Mounting Brackets with Hardware

## Universal Bracket

Universal Bracket 15000370	
QTY	Description
2	Bolt, 3/8-16 UNC x1 in.
2	Nut, 3/8-16
2	Lock Washer, 3/8 I.D.
4	Flat Washer, 3/8 I.D.

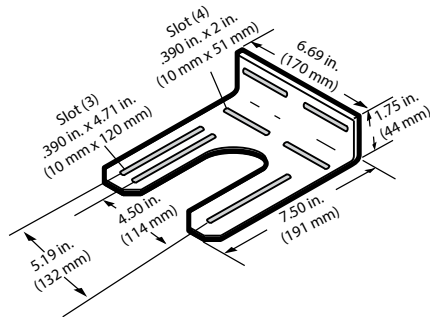

## Pipe Bracket

Pipe Bracket 15000371	
QTY	Description
2	Bolt, 3/8-16 UNC x 1 in.
2	Hex Nut, 3/8-16
2	Lock Washer, 3/8 I.D.
2	Flat Washer, 3/8 I.D.
2	Screw 1/4-20 x 1 in.
2	Lock Washer 1/4 in. I.D.
2	Hex Nut 1/4-20 x 7/16 in.

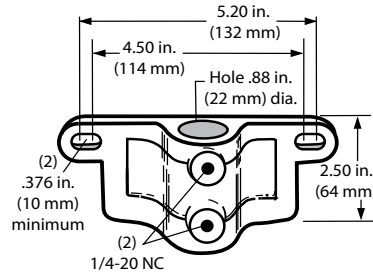

## Base Model Descriptions

**LM300:** Level Maintainer only (no switches).

**NOTE:** LM301, LM302 and LM303 are available in explosion-proof enclosure.

**LM301:** Low switch contacts for low-level shutdown or alarm. Four wires, SPDT.

**LM302:** Two switches for low-and high-level shutdown or alarm. Four wires, DPST, wired N.O. in normal operating ranges.

**LM303:** Two switches for low-and high-level shutdown or alarm. Four wires, DPST, wired N.C. in normal operating ranges.

**LM304:** Two switches. Alarm before shutdown on low level and shutdown on low-low level. Four wires, DPST, wired N.O. in normal operating ranges.

**LM305:** Two switches. Alarm before shutdown on low level and shutdown on low-low level. Four wires, DPST, wired N.C. in normal operating ranges.

## How to Order

Use the Model Number Chart to build a model number for your application. Call your sales representative or FW Murphy for more information, parts availability and ordering.

## Model Number Chart

When ordering a new complete unit, the Glass Lens option is available on the LM301 and LM301-EX models.

The Glass Lens Kit can be used on any LM300 Series body. See Additional Order Items.

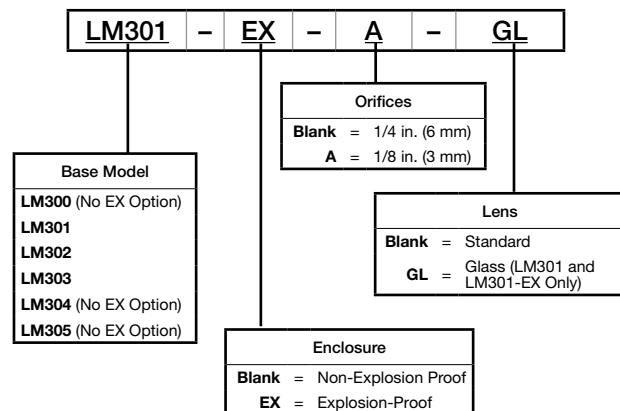

Approximate Shipping Weight and Dimensions		
Model	Weight	Dimension
LM300 Series non-EX	6 lbs. 6 oz. (2.89 kg)	10-5/8 x 8-7/8 x 6-3/4 in. (270 x 225 x 171 mm)
LM300 Series EX	6 lbs. 12 oz. (3.06 kg)	

## Additional Order Items

Part Number	Description
15000370	Universal Bracket Kit
15000371	Pipe Bracket Kit
15000354	Bubble Lens Assembly
15000355	Hose Kit
15000539	Glass Lens Kit (All LM300 Series)
15000357	Regulator Float Repair Kit

15000355 Hose Kit Parts	
Quantity	Description
1	1/2 in. (13 mm) I.D. x 3 ft. (914 mm) long hose
1	1 in. (25 mm) I.D. x 3 ft. (914 mm) long hose
2	1/2 in. (13 mm) worm gear clamp
2	1 in. (25 mm) worm gear clamp
2	1/2 NPT x 1/2 in. (13 mm) barbed fitting
2	3/4 NPT x 1 in. (25 mm) barbed fitting